

## SLANTED RAIL 4,8m

Catalogue number: 100948

It shall apply from: 17-12-2021

**Product dimensions:**  
(length x width x height) 4800 x 60 x 600 mm



### Overall dimensions

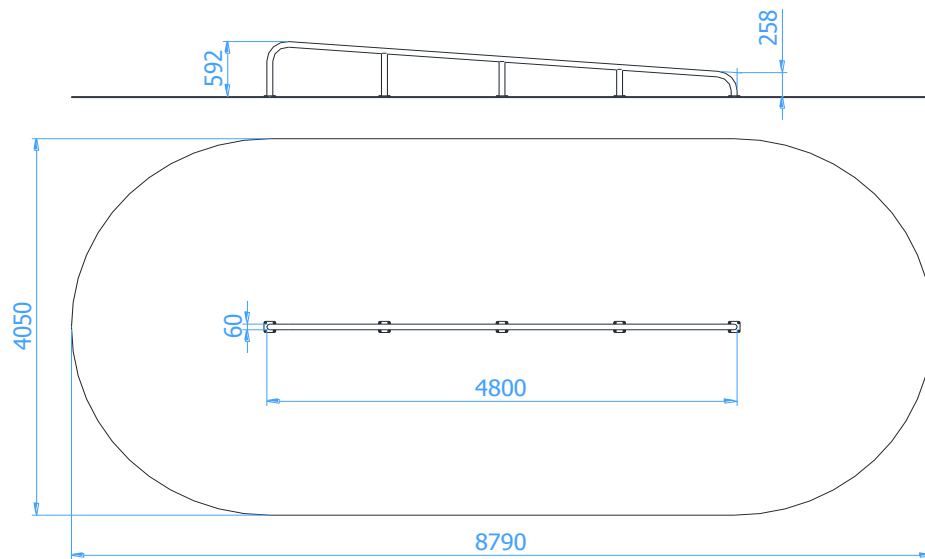

### Technical description

- Construction made of steel pipes: 60,3x2,9mm
- All steel elements are hot dip galvanized
- The Rail shall be installed on a hardened ground