



It shall apply from: **08-01-2016 r.**

THE ASSEMBLY INSTRUCTION OF:

Curb for box

PRODUCT CODE:

132070/132098



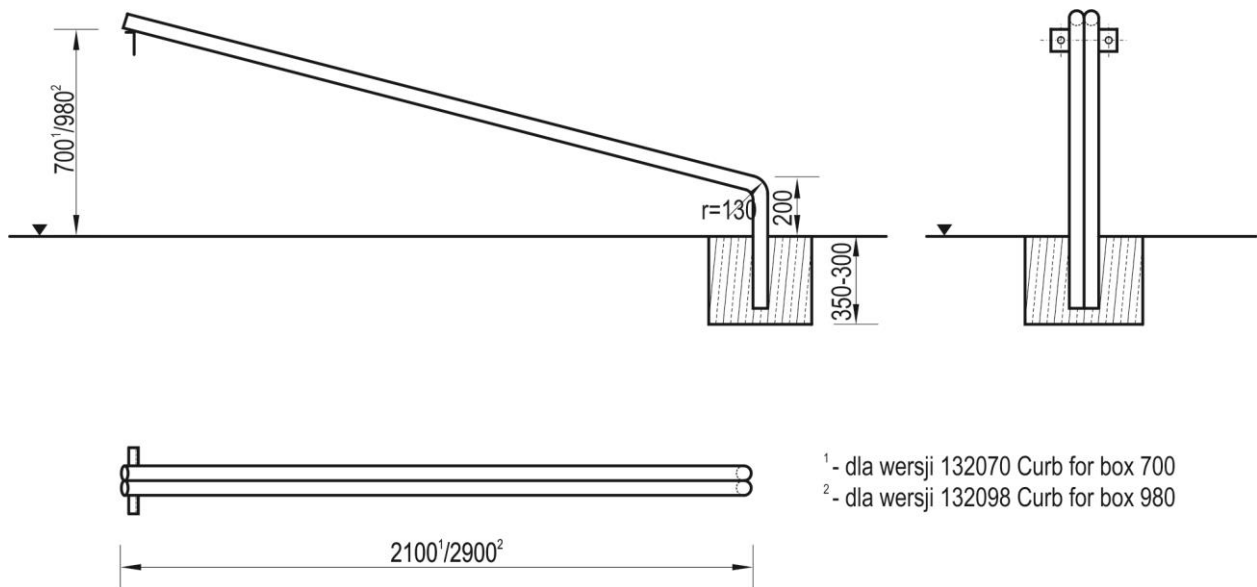

TABLE OF CONTENTS

INTRODUCTION	2
STAGE 1 – Preparatory work, safety zone	2
STAGE 2 – Assembly of the construction	3
1. List of components	3
2. Assembly scheme	3

INTRODUCTION

- Depth of foundation: 0,35 m



STAGE 1 – Preparatory work, safety zone

- Secure the assembly site to keep others at a distance
- Set the construction in a designated place having regard to required impact area.

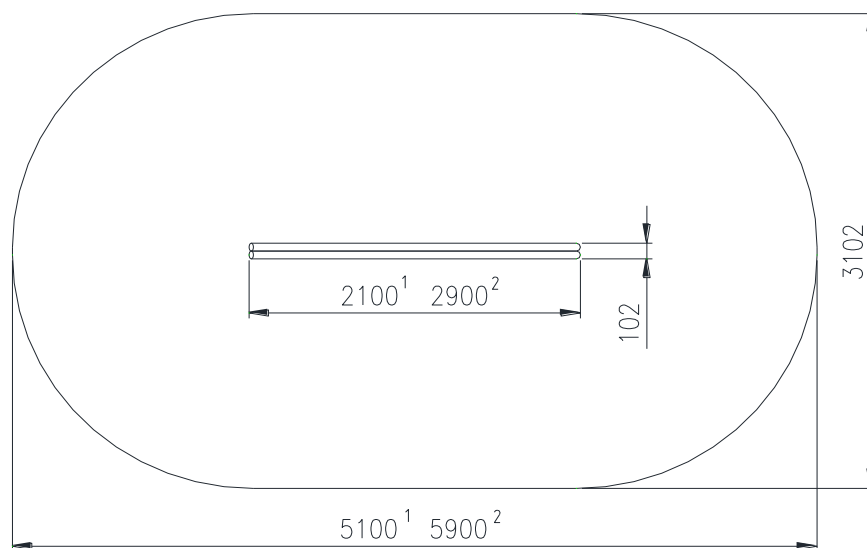

¹ – for variant 132070 Curb for box 700
² – for variant 132098 Curb for box 980

ASSEMBLY INSTRUCTION

Product code: 132070/132098 Curb for box



WARNING!

Installation shall be performed in accordance with safety & health standards
The position of concrete elements shall be set with a tolerance of ± 50 mm.

STAGE 2 - Assembly of the construction

1. List of components

No.	Name of component	Dimensions	Qty.	Norm
1	Box	1200x1200x700(980)	1	
2	Curb for box		1	
3	Steel frame		1	
4	Washer	$\text{Ø}30 \times \text{Ø}17 \times 3$	2	DIN 440
5	Washer	$\text{Ø}24 \times \text{Ø}1 \times 2,5$	4	DIN 440
6	Hexagon head screw	M16x25	2	DIN 933
7	Hexagon head screw	M12x80	2	DIN 931
8	Self-locking nut	M12	2	DIN 985

2. Assembly scheme

- Prepare an excavations of dimensions $\text{Ø}190 \times 300$ mm at a defined distance from the Boxes (point 1) to put there the steel frame for foundation (point 3). Fill the excavation with concrete of class C16/20.
- Screw the Curb for Box (point 2) to the Boxes (point 1) by using screws and washers of point 4 and 6.
- The lower end shall be screwed to the steel frame (point 16) with items of points 5, 7 and 8.
- Remove the slacks in joints
- Put the statutory plate

