

Assembly instruction



Product name:
Concrete Skate Bank Ramp - h 98 cm

Date create: 2014-05-22
Code: 151298

Destination:
Sport

Notes:
Freestanding

General principles

The device shall be mounted in accordance with the site layout plan or with the following principles:

- Secure the assembly site to keep others at a distance
- Designate a precise location of the assembly having regard to appropriate safety zones of all other devices.
- The device shall be mounted in consideration of an appropriate space of safety using of other, adjacent equipment, in accordance with the rules laid down in European Standard PN-EN 14974+A1:2010.
- During the assembly works, follow the original assembly instruction of the particular equipment.
- The item shall be mounted on a level ground, immediately after delivery to the mounting location.
- The installation shall be performed by using appropriate tools and technical means.

Assembly method

1. The assembly of the Bank shall start with planning of placing the device in area, having regard to its impact area (if determined) For this purpose use a tape measure, having regard to routes around the item.
2. Screw the steel toe plate to the edge of the Bank by using 6 countersunk screws M8x14 and 2 screws M10x20 with washer M10.
3. Screw the side rails to the sides of the Bank by using screws M10x25 and washers M10.

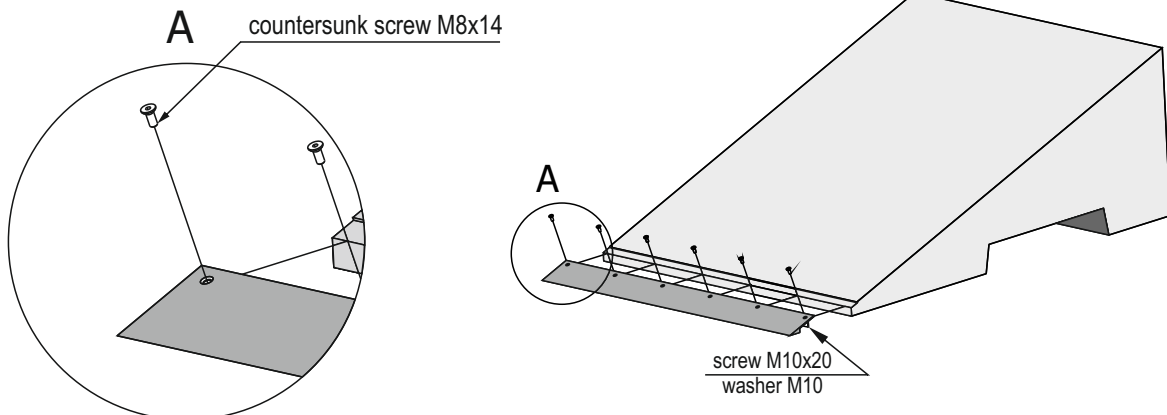

Rys. 1 Steel toe plate assembly scheme.

3. Set the construction in the designated place, on a levelled ground, according to the figure below

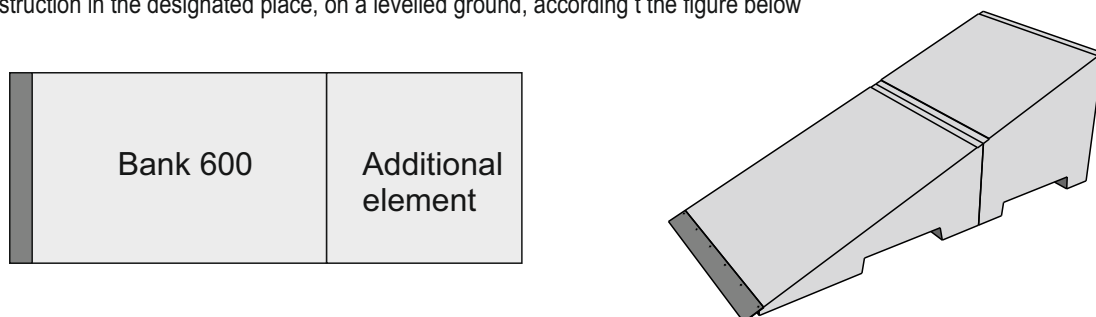

Fig. 2 Concrete elements setup

4. Fix the additional element and Bank 600 together by using sheet metal plate and countersunk screws M10x20.

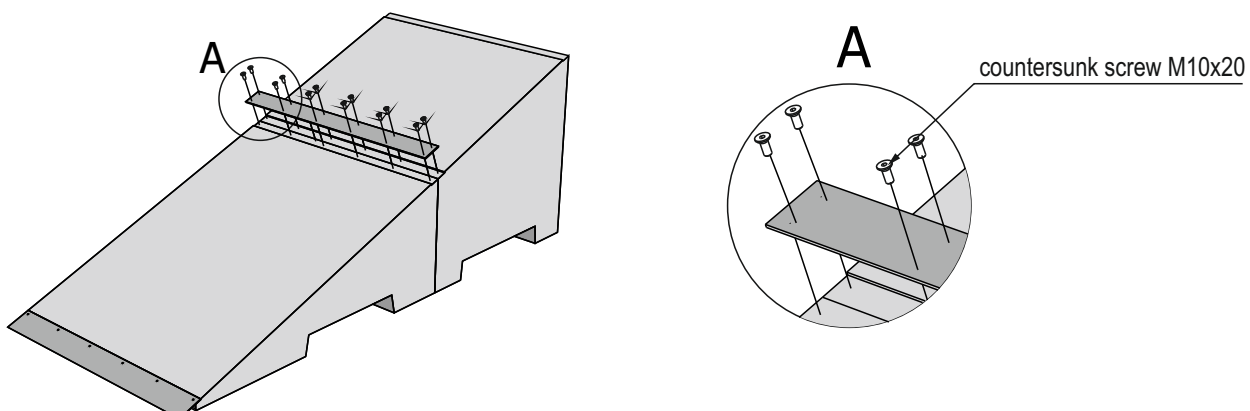

Fig. 3 The additional element and Bank 600 connecting scheme.

WARNING ! Children are allowed to use the item only under supervision of adults.