

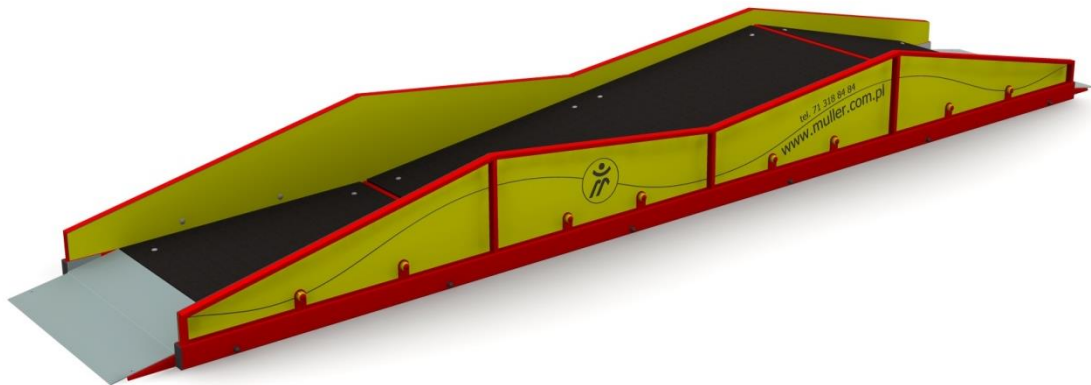

It shall apply from **17-04-2020**

ASSEMBLY INSTRUCTION:

2237 WHEELCHAIR ACCESSIBLE SEESAW





CONTENTS

PROEM	Błąd! Nie zdefiniowano zakładki.
STAGE 1 – Preparatory work	3
STAGE 2 – Installation.....	3
1. List of components	3
2. Assembly scheme	Błąd! Nie zdefiniowano zakładki.

PROEM

- Maximum free fall height: 0,37 m
- Depth of laying foundations: 0,15 m
- Impact area: 7,8 x 3,88 m

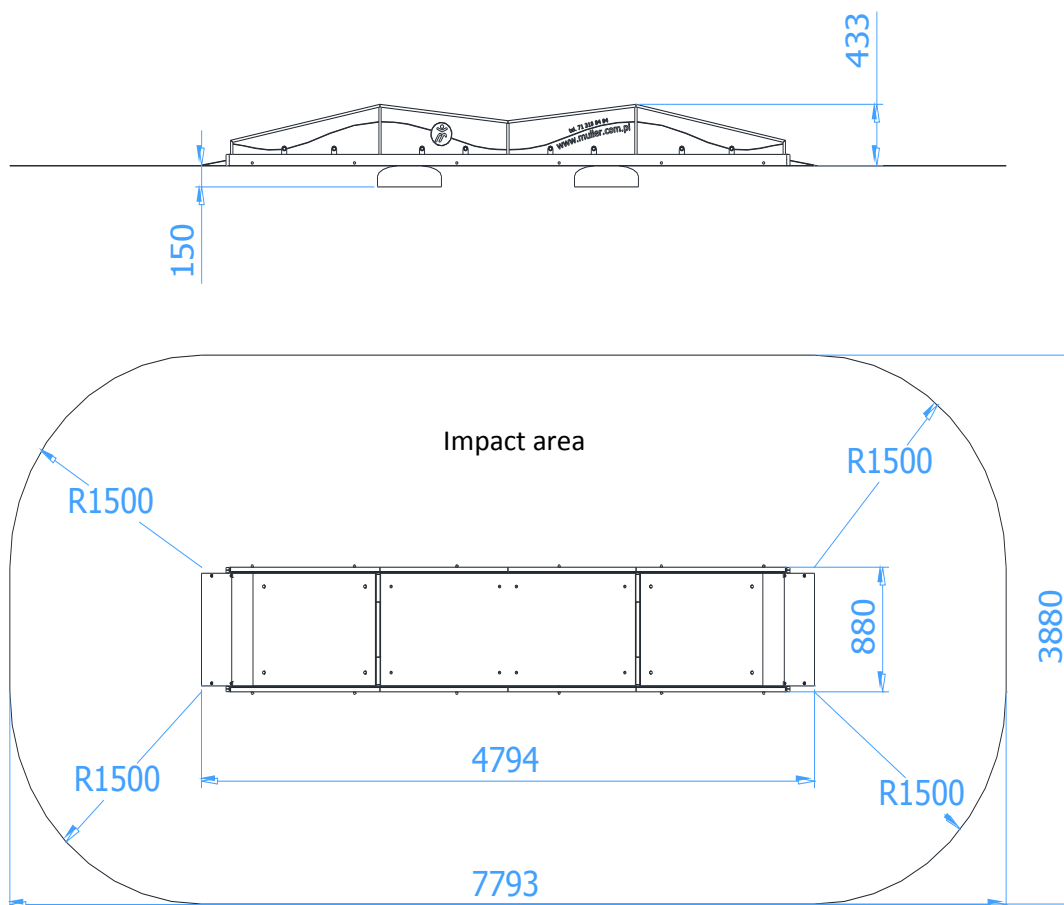



STAGE 1 – Preparatory work

- Secure the assembly site to keep others at a distance
- Position the construction in the selected location while maintaining required impact area
- Mark approximately points of contact between stanchions and the ground.

Foundations positions:

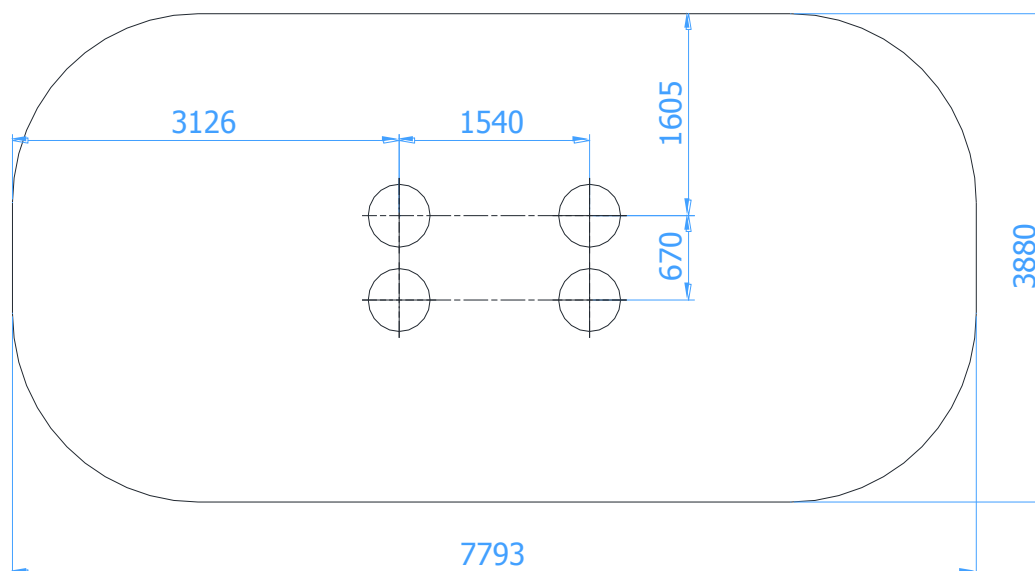

WARNING !

All installation activities shall be performance in accordance with health and safety regulations
 A foundations positions tolerance is ± 50 mm.

Stage 2 – Installation

1. List of components

No	NAME OF COMPONENT	DIMENSIONS	PC.	NORM
1	Ramp Seesaw		1	
2	Foundation	O500-1D	4	
3	Hexagonal Screw	M16 x 30	4	DIN 933
4	Washer	$\varnothing 30 \times \varnothing 17 \times 3$ (M16)	4	DIN 125



2. Assembly scheme

- Determine foundations position
- Turf (if any) shall be removed and set aside
- Excavate holes for foundations with a depth of 150mm
- Put the foundations into the holes (point 2)
- Set the device (point 1) on the foundations (point 2)
- Dismount the central panel according to the figure below

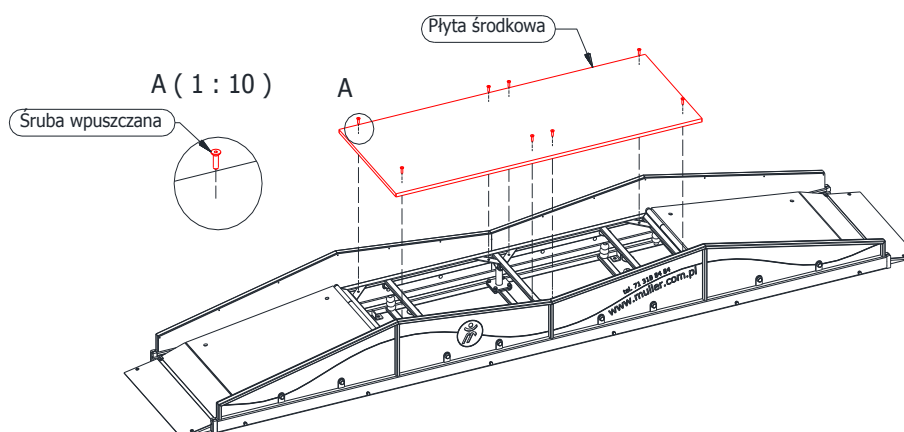

- Screw the device (point 1) to the foundations (point 2) with the screws (point 3 and 4).

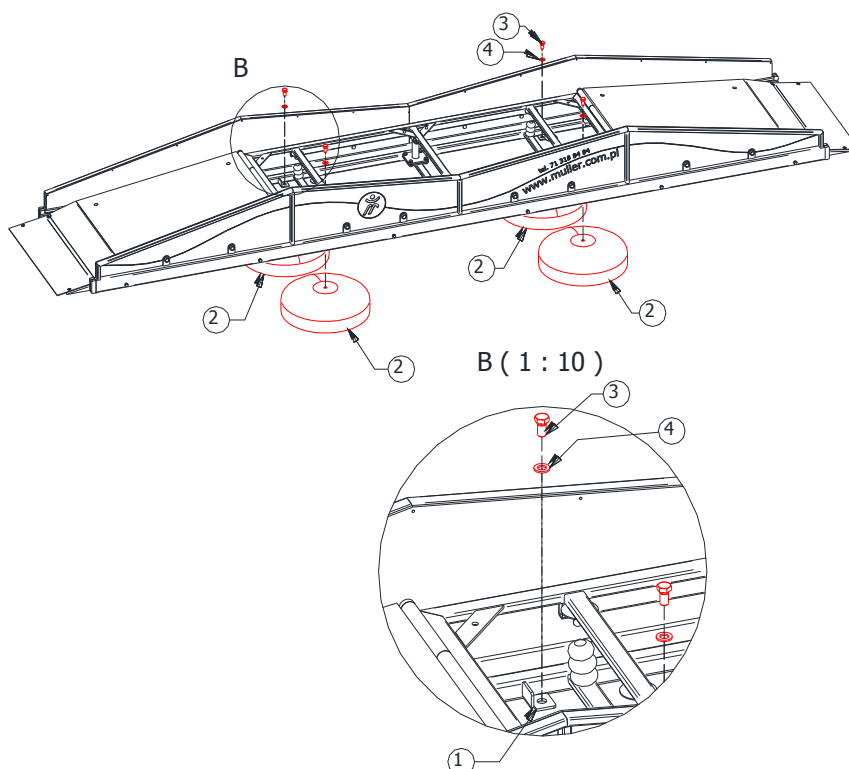

- Mount the central panel according to the figure
- Fill the holes with ground, compact and level it by the turf (if any) to the ground level
- Mount the statutory plate