

SYSTEM
TYTAN

BUTTERFLY

Catalogue number: 26059

It shall apply from: 24-01-2024

Max. free fall height:	0,41 m
Product dimensions (length x width x height)	0,83 x 0,85 x 1,81 m
Impact area dimensions: (length x width)	3,83 x 3,85 m
Free zone:	12,6 m ²



Product dimensions

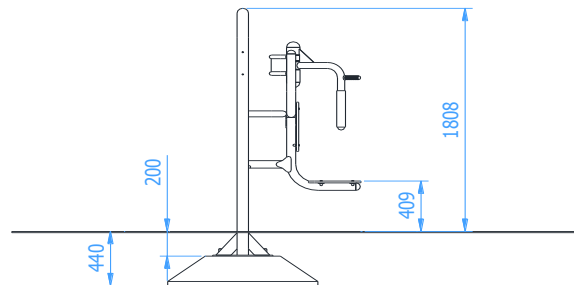

Impact area dimensions

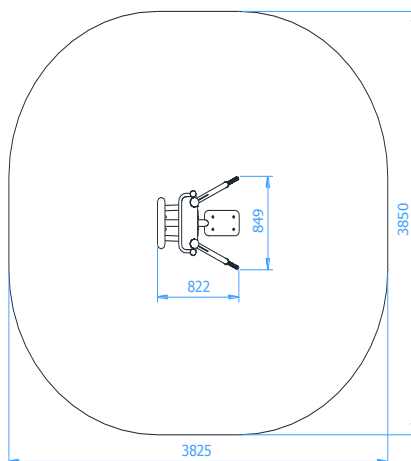

Acceptable shock-absorbing surface:

- No requirements

Technical description

- A solid steel construction made of round pipes $\varnothing 60,3 \times 2,9 \text{ mm}$
- The seat and the back rest made of durable 15mm HDPE sheet
- An arm of the device made of $\varnothing 48,3 \times 2,9 \text{ mm}$ pipe with a handle of $\varnothing 16$ rod covered by an artificial material
- Automatic, maintenance-free rubber stringing units provide incremental rise of resistance of gym device
- The device is equipped with hydraulic shock absorbers providing seamless motion and safety return to starting position
- All steel elements are hot-dip galvanized and painted with an acrylic, structured lacquer
- The device should be mounted to the Pylon of Tytan System series

TECHNICAL DATA SHEET

Working Muscles:

