

8-STATION MULTI GYM ATLAS

Catalogue number: 26080

It shall apply from: 24-01-2024

Max. free fall height:	0,90 m
Product dimensions: (length x width x height)	4,16 x 4,16 x 2,50 m
Impact area dimensions: (length x width)	7,08 x 7,08 m
Free zone:	39,3 m ²



Product dimensions

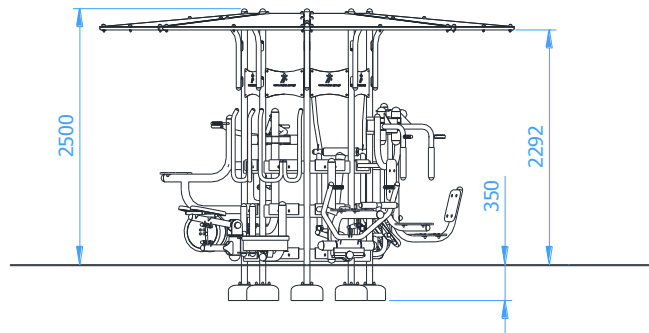

Impact area dimensions

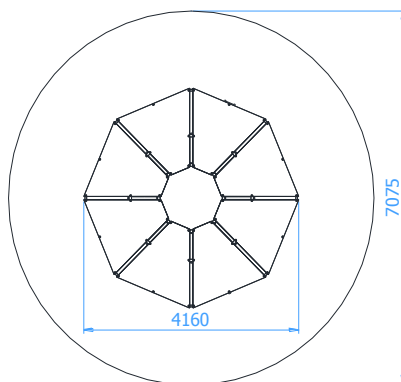

Acceptable shock-absorbing surface:

- No requirements

Technical description

- A frame of the multi gym station made of $\varnothing 60,3 \times 2,9$ mm pipe and profiles 120x40x3 mm
- The gym station equipped with 8-station pylon with shading structure and 8 different gym devices: 26059 Butterfly, 26069 Leg Press, 26109 Rower, 26259 Standing Twister, 26359 Lat Pull Down, 26559 Elliptical Cross Trainer, 26609 Ski Slalom Trainer, 26759 Spinning Bike
- 6mm HPL information boards with logo and a space for instruction
- All steel elements are hot-dip galvanized and painted with an acrylic, structured lacquer
- Includes a foundation made of concrete of class C25/30 which make installation easier

TECHNICAL DATA SHEET

Product visualization

