

SYSTEM
TYTAN

EXERCISE BENCH

Catalogue number: 26459

It shall apply from: 24-01-2024

Max. free fall height:	0,84 m
Product dimensions (length x width x height)	1,55 x 0,60 x 1,81 m
Impact area dimensions: (length x width)	4,55 x 3,60 m
Free zone:	14,1 m ²



Product dimensions

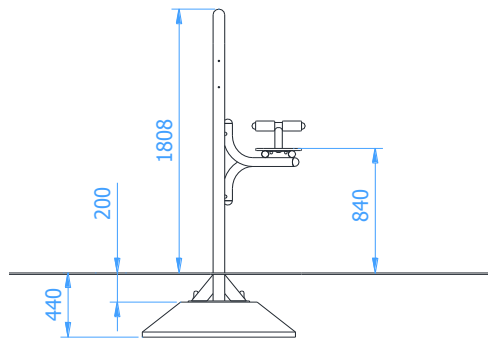

Impact area dimensions

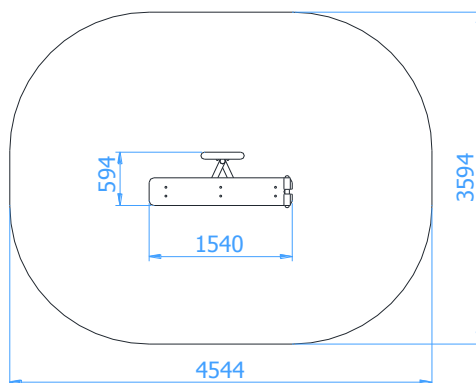

Acceptable shock-absorbing surface:

- No requirements

Technical description

- A solid steel construction made of round pipes $\varnothing 60,3 \times 2,9 \text{ mm}$
- The seat and the back rest made of durable 15mm HDPE sheet
- The leg rests made of $\varnothing 48,3 \times 2,9 \text{ mm}$ pipe covered by an artificial material
- All steel elements are hot-dip galvanized and painted with an acrylic, structured lacquer
- The device should be mounted to the Pylon of Tytan System series

TECHNICAL DATA SHEET

Working muscles

