

**SYSTEM**  
**TYTAN**

## SKI SLALOM TRAINER

Catalogue number: 26609

It shall apply from: 24-01-2024

<b>Max. free fall height:</b>	0,58 m
<b>Product dimensions</b> (length x width x height)	0,78 x 0,47 x 1,81 m
<b>Impact area dimensions:</b> (length x width)	3,78 x 3,53 m
<b>Free zone:</b>	11,1 m <sup>2</sup>



### Product dimensions

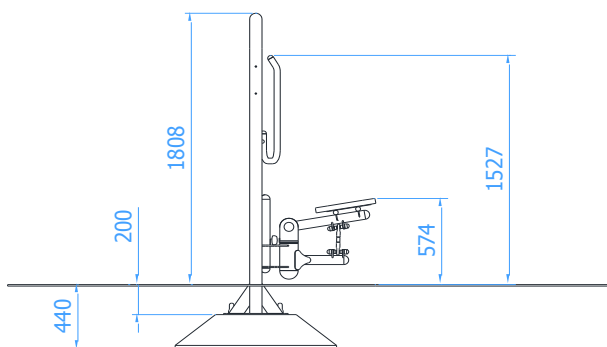

### Impact area dimensions

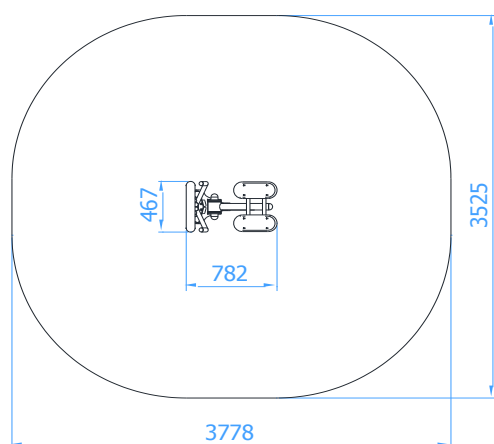

Acceptable shock-absorbing surface:

- No requirements

### Technical description

- A solid steel construction made of round pipe  $\varnothing 88,9 \times 3,2$ mm
- The leg rests made of  $\varnothing 57 \times 2,9$ mm pipe with anti-slip footrests of epoxy resin
- The handles made of  $\varnothing 38 \times 2,6$ mm pipe provides stable support during exercises
- The device mechanism bases on bearings which shall not require a maintenance
- All steel elements are hot-dip galvanized and painted with an acrylic, structured lacquer
- The device should be mounted to the Pylon of Tytan System series

## TECHNICAL DATA SHEET

### Working muscles

