

# TECHNICAL DATA SHEET

## TARANTULA SEESAW

Catalogue number: 81401

<b>Users' age group:</b>	3 to 14 years
<b>Max. free fall height:</b>	0,95 m
<b>Product dimensions:</b> (length x width x height)	2,91 x 1,52 x 0,81 m
<b>Impact area dimensions:</b> (length x width)	5,00 x 2,75 m



### Product dimensions

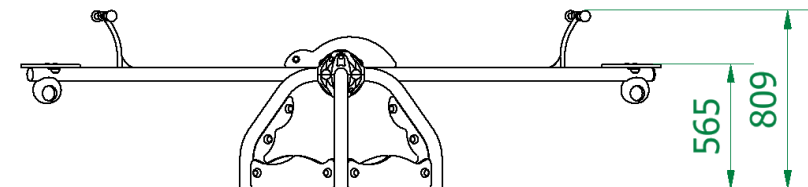

### Impact area dimensions

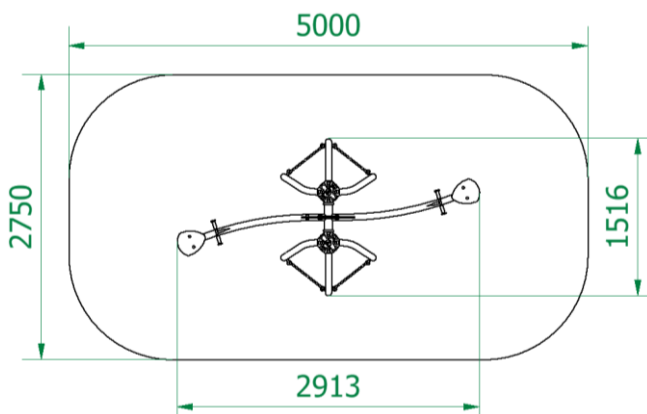

### Permissible impact attenuating surface

- Turf / topsoil
- Bark – grain size 20 do 80 mm, min. depth 200 mm + 100mm (for displacement)
- Woodchip – grain size 5 do 30 mm, min. depth 200mm + 100mm (for displacement)
- Sand – grain size 0,2 do 2 mm, min. depth 200mm + 100mm (for displacement)
- Gravel – grain size 2 do 8 mm, min. depth 200 mm + 100mm (for displacement)
- Synthetic surfaces in accordance with tested HIC (EN 1177)

*The impact attenuating surfacing shall be installed over the entire impact area.*

### Technical description

- Construction made of stainless steel and plastic connectors.
- HDPE and HPL construction components
- The seat made of HDPE sheet
- The set includes foundations made of concrete class C25/30