

CASTLE PLAYGROUND SET NO. 06

Catalogue number: 83006

Users' age group:	6 - 14 years
Max. free fall height :	1,9 m
Product dimensions: (length x width x height)	9,61 x 7,41 x 4,63 m
Impact area dimensions: (length x width)	12,44 x 10,56 m



Product dimensions

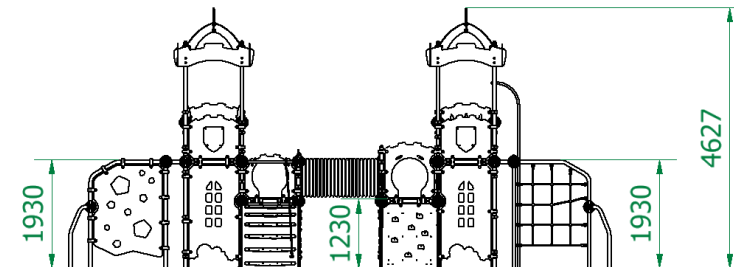

Impact area dimensions

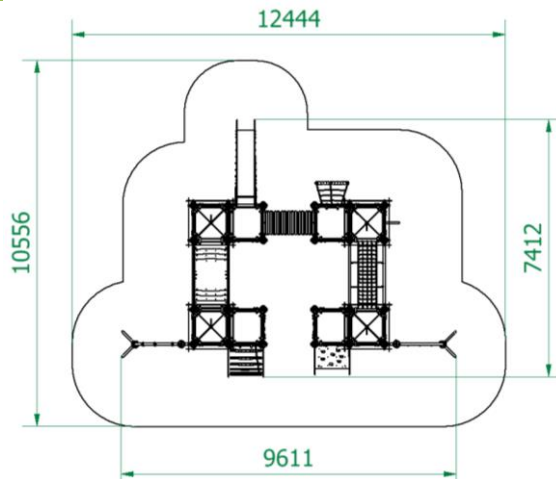

Permissible impact attenuating surface

- Bark – grain size 20 do 80 mm, min. depth 200 mm + 100mm (for displacement)
- Woodchip – grain size 5 do 30 mm, min. depth 200mm + 100mm (for displacement)
- Sand – grain size 0,2 do 2 mm, min. depth 200mm + 100mm (for displacement)
- Gravel – grain size 2 do 8 mm, min. depth 200 mm + 100mm (for displacement)
- Synthetic surfaces in accordance with tested HIC (EN 1177)

The impact attenuating surfacing shall be installed over the entire impact area.

Technical description

- Construction made of stainless steel and plastic connectors.
- HDPE and HPL construction components
- Non-slip, waterproof plywood platforms
- Stainless steel & HDPE slide
- PP corrugated pipe
- Ø16 mm PP ropes with galvanized steel wires
- The set includes foundations made of concrete class C25/30