

STREET WORKOUT SET NO. 31

Catalogue number: 88031

It shall apply from: 22-01-2024

Max. free fall height:	1,87 m
Product Dimensions: (length x width x height)	7,80 x 5,45 x 2,90 m
Impact area: (length x width)	10,76 x 8,73 m
Free zone:	71,4 m



Product dimensions

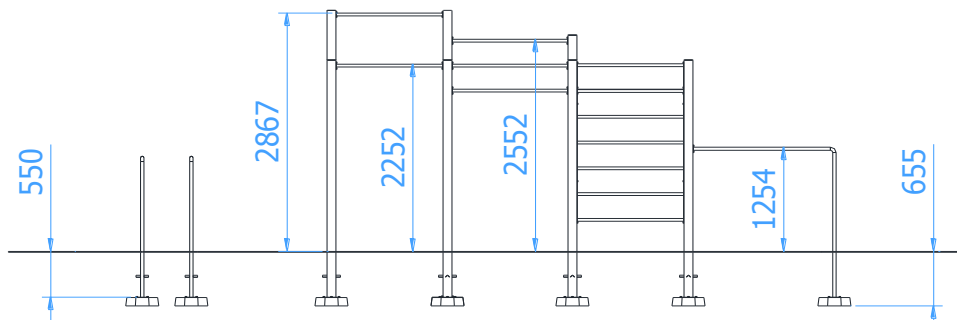

Impact area dimensions

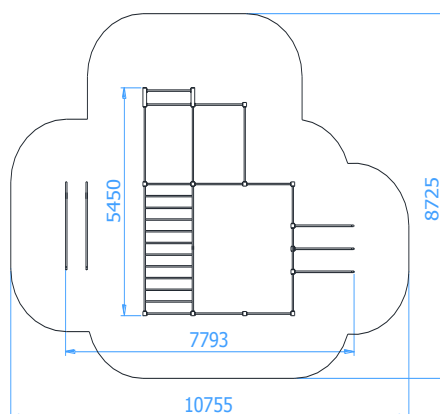

Permissible impact attenuating surface

- Bark – grain size 20 do 80mm, min. depth 200
- Woodchip – grain size 5 do 30 mm, min. depth 200mm
- Sand – grain size 0,2 do 2 mm, min. depth 200mm
- Gravel – grain size 2 do 8 mm, min. depth 200 mm
- Synthetic surfaces in accordance whit tested HIC (EN 1177)

*The impact attenuating surfacing shall be installed on the whole of impact area.
A loose-fill safety surface shall be 100mm thicker than min. depth indicated above.*

Technical description

- All posts made of closed profiles 100x100x3mm
- Bars and ladders made of $\varnothing 33,7 \times 4$ mm pipes
- Horizontal ladder made of pipes: $\varnothing 38 \times 4$ mm and $\varnothing 33,7 \times 4$ mm,
- Parallel bars made of $\varnothing 38 \times 4$ mm pipe
- All steel elements are hot-dip galvanized and painted with an acrylic, structured lacquer
- The set includes foundations made of concrete class C25/30
- All posts shall be set in concrete class C16/20

TECHNICAL DATA SHEET

Components of the Set

- Horizontal ladder – 1pc.
- Ladder – 1pc.
- Exercise pole – 1pc.
- Pull-up bar – 9pcs.
- Triple parallel bars – 1set.
- Double parallel bars – 1set

Product visualization

