

## STREET WORKOUT & PARKOUR SET NO. 3

Catalogue number: 88503

It shall apply from: 24-01-2024

<b>Max. free fall height:</b>	2,06 m
<b>Product Dimensions:</b> (length x width x height)	7,50 x 5,33 x 3,90 m
<b>Impact area:</b> (length x width)	10,49 x 8,33 m
<b>Free zone:</b>	71,8 m <sup>2</sup>

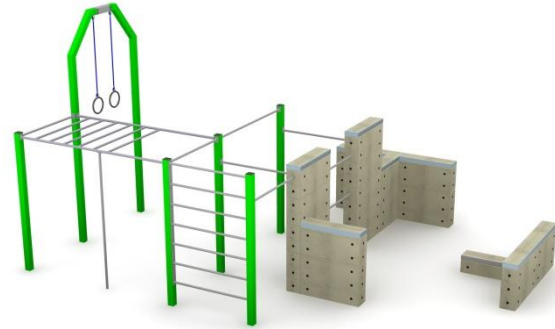

### Product dimensions

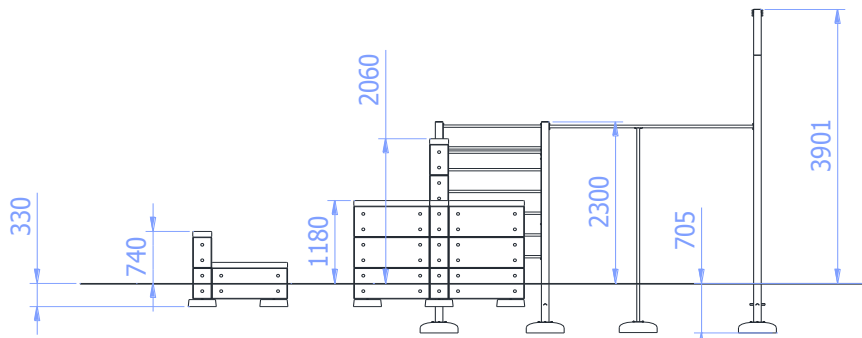

### Impact area dimensions

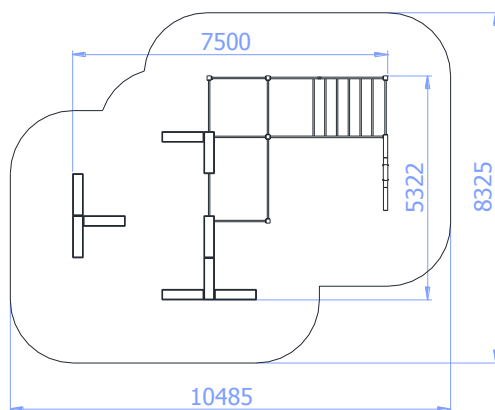

### Permissible impact attenuating surface

- Bark – grain size 20 do 80mm, min. depth 200
- Woodchip – grain size 5 do 30 mm, min. depth 200mm
- Sand – grain size 0,2 do 2 mm, min. depth 200mm
- Gravel – grain size 2 do 8 mm, min. depth 200 mm
- Synthetic surfaces in accordance whit tested HIC (EN 1177)

*The impact attenuating surfacing shall be installed on the whole of impact area.*

*A loose-fill safety surface shall be 100mm thicker than min. depth indicated above.*

### Technical description

- All posts made of closed profiles 100x100x3mm
- Bars and ladder made of  $\varnothing 33,7 \times 4$ mm pipes
- Horizontal ladder made of pipes:  $\varnothing 38 \times 4$ mm and  $\varnothing 33,7 \times 4$ mm
- Blocks made of concrete class C16/20
- All steel elements are hot-dip galvanized and painted with an acrylic, structured lacquer
- The set includes foundations made of concrete class C25/30
- All posts shall be set in concrete class C16/20

# TECHNICAL DATA SHEET

## Product visualization

