

STREET WORKOUT & PARKOUR SET NO. 4

Catalogue number: 88504

It shall apply from: 15-07-2024

Max. free fall height:	2,06 m
Product Dimensions: (length x width x height)	9,75 x 4,97 x 3,90 m
Impact area: (length x width)	12,75 x 7,95 m
Free zone:	83,9 m ²

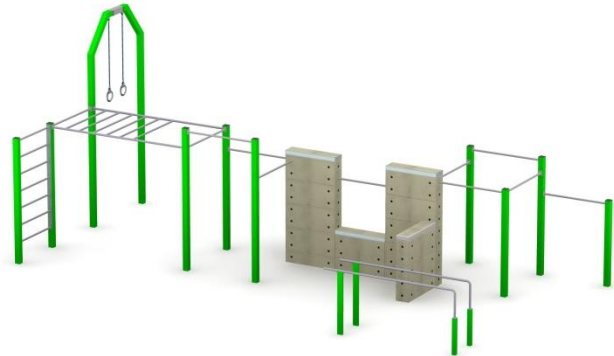

Product dimensions

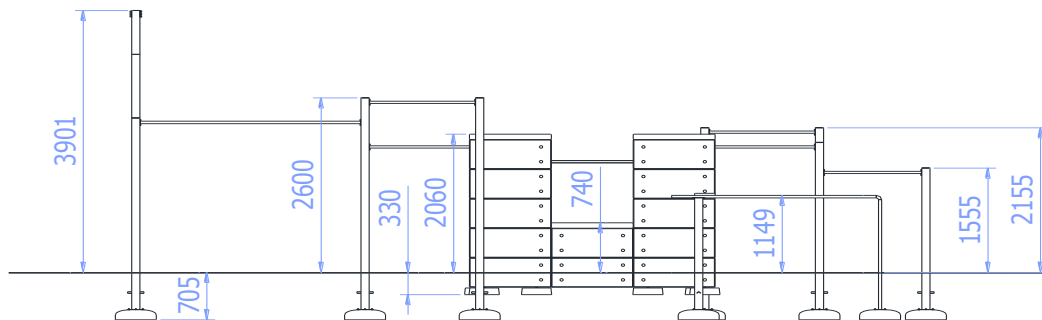

Impact area dimensions

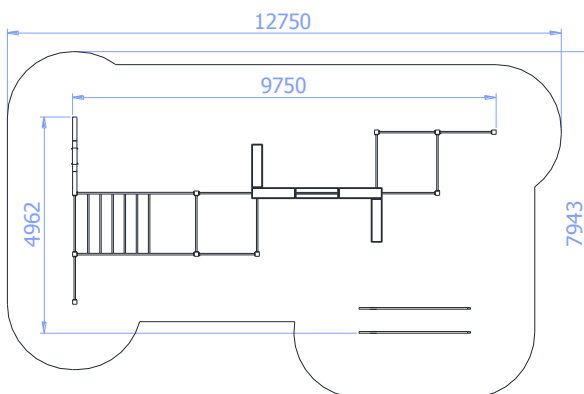

Permissible impact attenuating surface

- Bark – grain size 20 do 80mm, min. depth 200
- Woodchip – grain size 5 do 30 mm, min. depth 200mm
- Sand – grain size 0,2 do 2 mm, min. depth 200mm
- Gravel – grain size 2 do 8 mm, min. depth 200 mm
- Synthetic surfaces in accordance whit tested HIC (EN 1177)

The impact attenuating surfacing shall be installed on the whole of impact area.

A loose-fill safety surface shall be 100mm thicker than min. depth indicated above.

Technical description

- All posts made of closed profiles 100x100x3mm
- Bars and ladder made of $\varnothing 33,7 \times 4$ mm pipes
- Horizontal ladder made of pipes: $\varnothing 38 \times 4$ mm and $\varnothing 33,7 \times 4$ mm
- Blocks made of concrete class C16/20
- Gymnastic rings made of stainless steel pipe $\varnothing 30 \times 2$ mm and armed rope $\varnothing 16$ mm
- All steel elements are hot-dip galvanized and painted with an acrylic, structured lacquer
- The set includes foundations made of concrete class C25/30
- All posts shall be set in concrete class C16/20

TECHNICAL DATA SHEET

Product visualization

