

## BOX S1 CLIMBING CUBE

Catalogue number: 89202

<b>Users' age group:</b>	7+
<b>Max. free fall height :</b>	2,2 m
<b>Product dimensions:</b> (length x width x height)	2,66 x 2,65 x 2,23 m
<b>Impact area dimensions:</b> (length x width)	6,02 x 5,48 m
<b>Free zone:</b>	26,2 m <sup>2</sup>



### Product dimensions

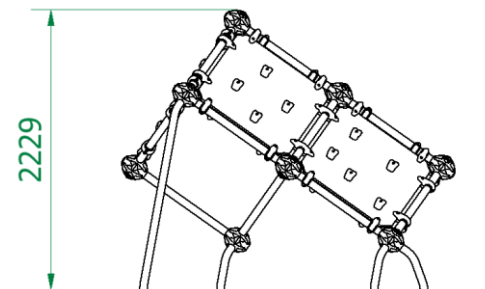

### Impact area dimensions

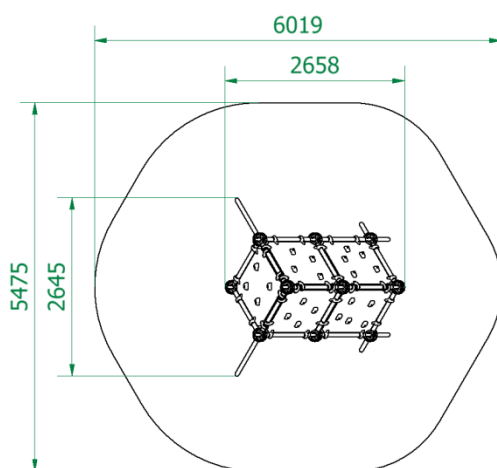

### Permissible impact attenuating surface

- Bark – grain size 20 do 80 mm, min. depth 300 mm + 100mm (for displacement)
- Woodchip – grain size 5 do 30 mm, min. depth 300mm + 100mm (for displacement)
- Sand – grain size 0,2 do 2 mm, min. depth 300mm + 100mm (for displacement)
- Gravel – grain size 2 do 8 mm, min. depth 300 mm + 100mm (for displacement)
- Synthetic surfaces in accordance with tested HIC (EN 1177)

*The impact attenuating surfacing shall be installed over the entire impact area.*

### Technical description

- Construction made of stainless steel and plastic connectors.
- HPL construction components
- Climbing grips made of epoxy resin
- The set includes foundations made of concrete class C25/30