

Technical Data Sheet

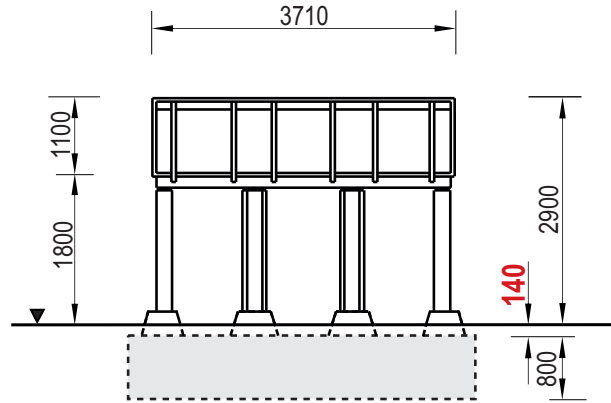

| | | | | |
|---|-----------------------------------|------------------------|-----------------------------------|-----------------------|
| Product name: Quarter Pipe Ramp - width 360 cm | Date create: 2018-02-01 | Code: 141808 | Destination: Skate Park | Scale: 1:25 |
| Construction materials: Concrete of class C 35/45, hot dip galvanized steel | Weight: 9350 | Notes: | | |

The device intended for the installation on a skate park surface, foundations required.

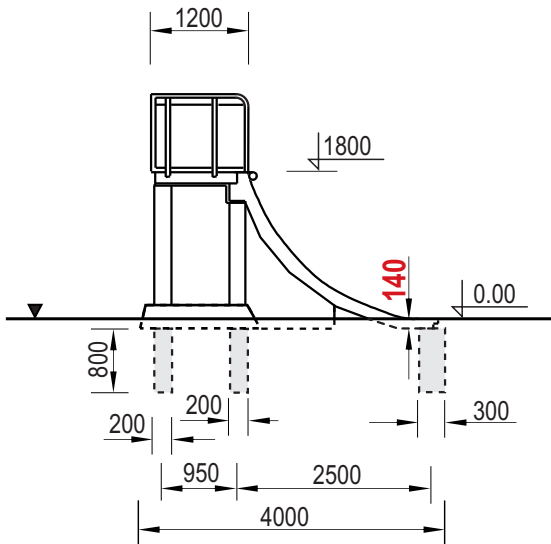

Foundations setup

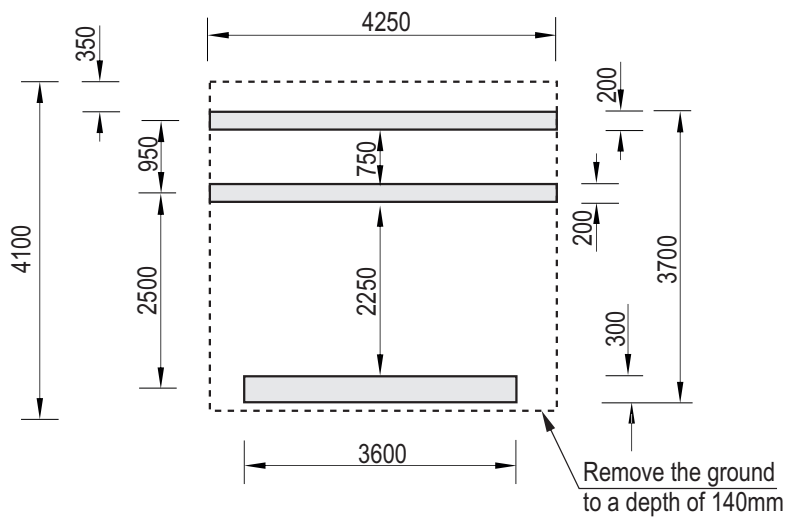
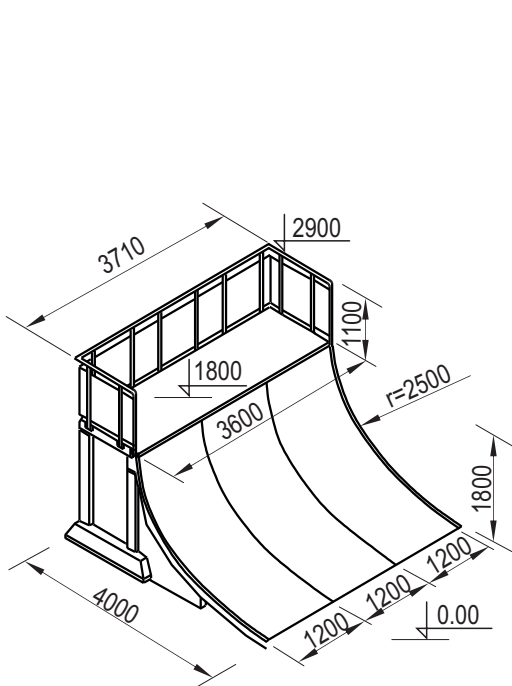

Technical description:

- Construction made of concrete of class C35/45, steel pipes and steel sheet,
- Upper barrier made of pipe $\varnothing 48,3 \times 2,9$ mm and steel sheet 3mm,
- Side rails made of pipes $\varnothing 35 \times 2$ mm,
- All steel elements protected against corrosion (hot dip galvanized),
- The equipment is certified according to PN-EN 14974+A1/2010 Norm

WARNING ! The equipment shall be used in accordance with its intended purpose