

## RAMP 1250 – width 3,6m

Catalogue number: 193612

It shall apply from: 14-03-2023

**Product dimensions  
(length x width x height)** 8,26 x 3,60 x 2,45 m



### Product dimensions:

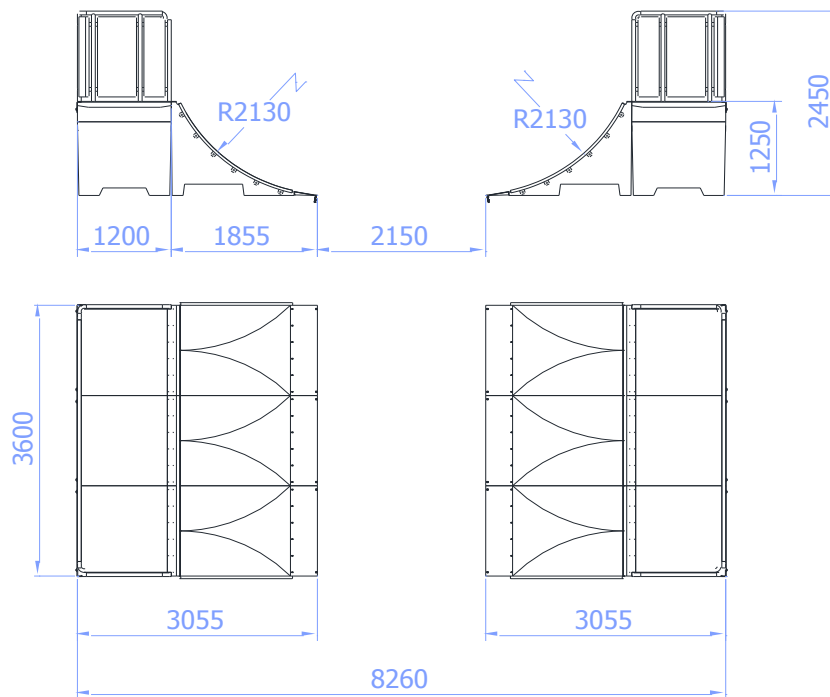

### Technical description

- Construction made of concrete of class C35/45,
- Barrier made of steel pipe  $\varnothing 48,3 \times 2,9$  mm and sheet metal 3 mm,
- Edge pipe made of pipe  $\varnothing 35 \times 2$  mm,
- The Ramp requires foundations of concrete of at least of class C16/20,
- The concrete elements are protected against weather conditions effects by impregnation preparation and painted with PILBET acrylic paint.