

RAMP 1250 – width 4,8m

Catalogue number: 194812

It shall apply from: 06-03-2023

Product dimensions
(length x width x height) 8,26 x 4,80 x 2,45 m



Product dimensions:

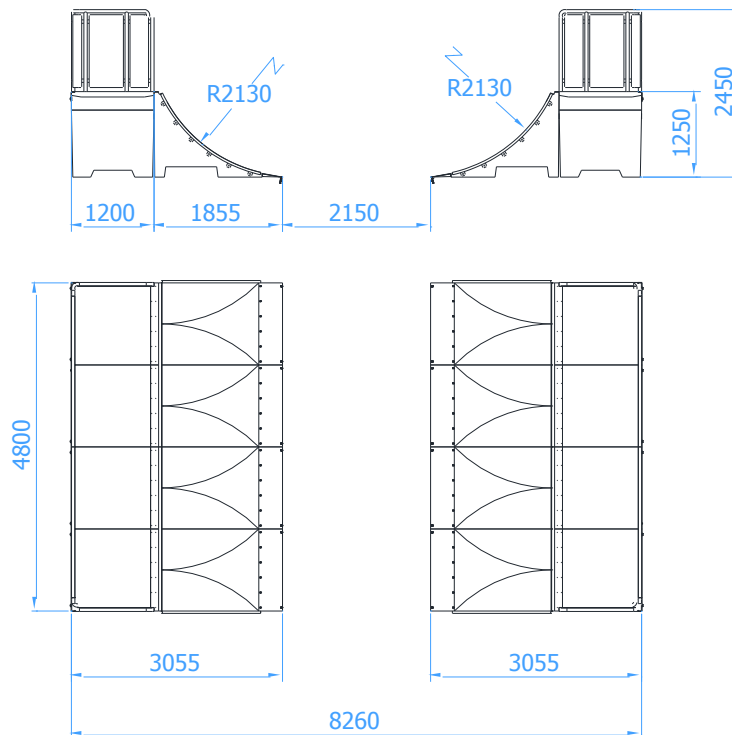

Technical description

- Construction made of concrete of class C35/45,
- Barrier made of steel pipe $\varnothing 48,3 \times 2,9$ mm and sheet metal 3 mm,
- Edge pipe made of pipe $\varnothing 35 \times 2$ mm,
- The Ramp requires foundations of concrete of at least of class C16/20,
- The concrete elements are protected against weather conditions effects by impregnation preparation and painted with PILBET acrylic paint.