

STREET WORKOUT SET NO. 9

Catalogue number: 88009

It shall apply from: 22-01-2024

Max. free fall height:	1,60 m
Product Dimensions: (length x width x height)	4,92 x 4,85 x 3,90 m
Impact area: (length x width)	7,90 x 8,01 m
Free zone:	57,9 m ²

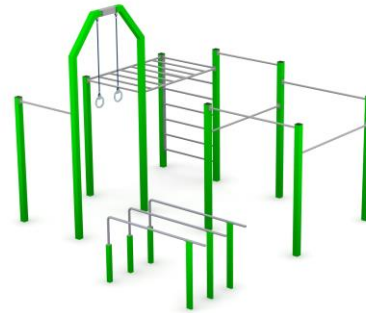

Product dimensions

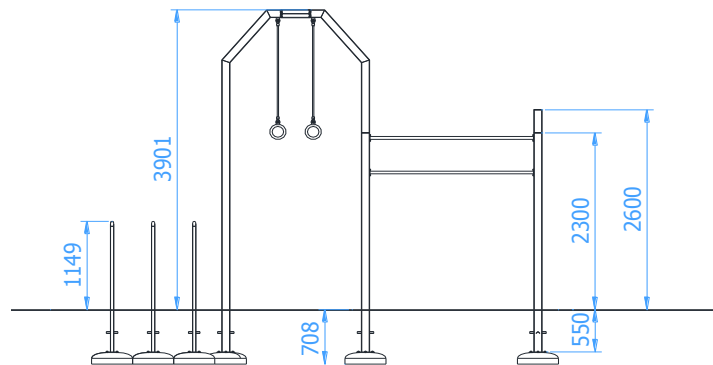

Impact area dimensions

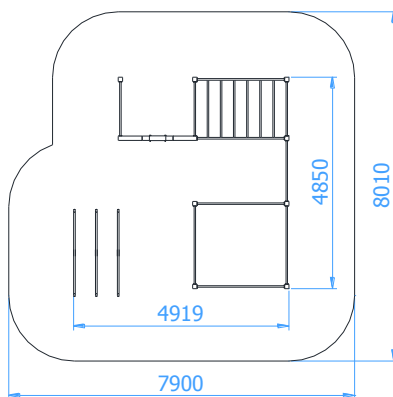

Permissible impact attenuating surface

- Bark – grain size 20 do 80mm, min. depth 200
- Woodchip – grain size 5 do 30 mm, min. depth 200mm
- Sand – grain size 0,2 do 2 mm, min. depth 200mm
- Gravel – grain size 2 do 8 mm, min. depth 200 mm
- Synthetic surfaces in accordance whit tested HIC (EN 1177)

The impact attenuating surfacing shall be installed on the whole of impact area.

A loose-fill safety surface shall be 100mm thicker than min. depth indicated above.

Technical description

- All posts made of closed profiles 100x100x3mm
- Bars and ladder made of Ø33,7x4mm pipes
- Horizontal ladder made of pipes: Ø33,7x4mm and Ø38x4mm
- Gymnastic rings made of stainless steel pipe Ø30x2mm and armed rope Ø16mm
- Parallel bars made of pipe Ø38,3x4mm and profiles 100x40x3mm, 70x70x3mm,
- All steel elements are hot-dip galvanized and painted with an acrylic, structured lacquer
- The set includes foundations made of concrete class C25/30
- All posts shall be set in concrete class C16/20

TECHNICAL DATA SHEET

Components of the Set

- Parallel bars – 1 set
- Ladder – 1 pc.
- Horizontal ladder – 1 pc.
- Gymnastic rings – 1 set
- Pull-up bars – 6 pcs.

Product visualization

