

STREET WORKOUT SET NO. 23

Catalogue number: 88023

It shall apply from: 05-08-2024

Max. free fall height:	2,80 m
Product Dimensions: (length x width x height)	6,02 x 5,38 x 3,90 m
Impact area: (length x width)	9,02 x 9,18 m
Free zone:	62,8 m ²



Product dimensions

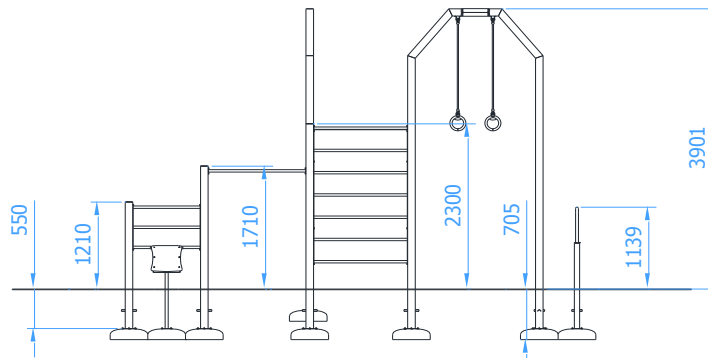

Impact area dimensions

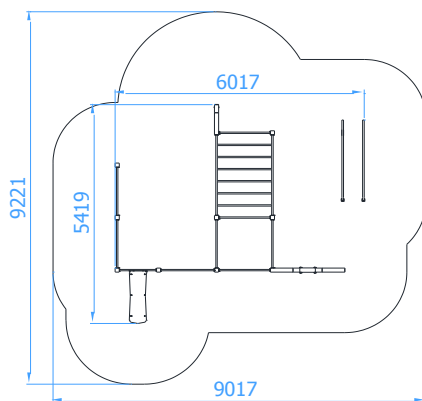

Permissible impact attenuating surface

- Bark – grain size 20 do 80mm, min. depth 200
- Woodchip – grain size 5 do 30 mm, min. depth 200mm
- Sand – grain size 0,2 do 2 mm, min. depth 200mm
- Gravel – grain size 2 do 8 mm, min. depth 200 mm
- Synthetic surfaces in accordance with tested HIC (EN 1177)

The impact attenuating surfacing shall be installed on the whole of impact area.

A loose-fill safety surface shall be 100mm thicker than min. depth indicated above.

Technical description

- All posts made of closed profiles 100x100x3mm
- Bars made of $\varnothing 33,7 \times 4$ mm pipes
- Parallel bars and ladders made of $\varnothing 38 \times 4$ mm pipe
- Seat of the exercise bench made of 15mm HDPE sheet
- Gymnastic rings made of stainless steel pipe $\varnothing 30 \times 2$ mm and armed rope $\varnothing 16$ mm
- $\varnothing 40$ mm jute climbing rope
- All steel elements are hot-dip galvanized and painted with an acrylic, structured lacquer
- The set includes foundations made of concrete class C25/30
- All posts shall be set in concrete class C16/20

TECHNICAL DATA SHEET

Components of the Set

- Horizontal ladder – 1pc.
- Ladder – 1pc.
- Parallel bars – 1set
- Gymnastic rings – 1pc.
- Exercise bench with small ladder – 1pc.
- Pull-up bar – 5pcs.

Product visualization

