

STREET WORKOUT SET NO. 35

Catalogue number: 88035

It shall apply from: 09-05-2024

Max. free fall height:	1,60 m
Product Dimensions: (length x width x height)	11,80 x 2,83 x 2,60 m
Impact area: (length x width)	14,81 x 5,58 m
Free zone:	65 m ²

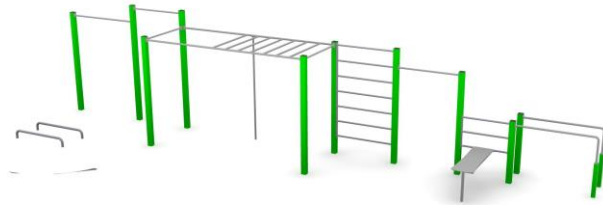

Product dimensions

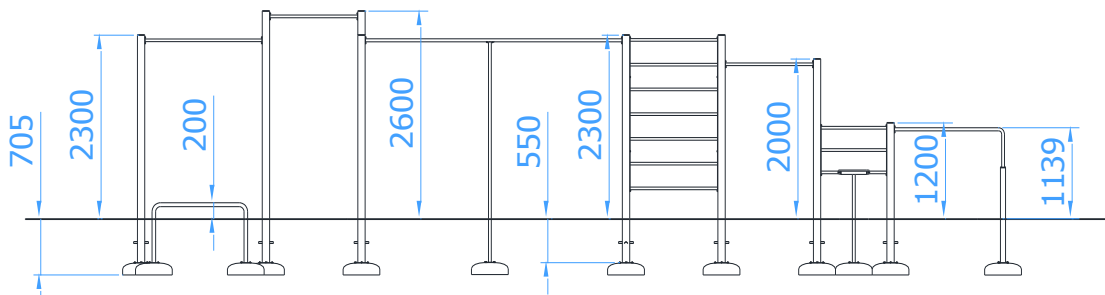

Impact area dimensions

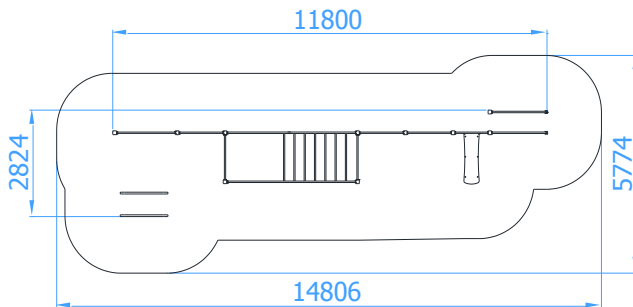

Permissible impact attenuating surface

- Bark – grain size 20 do 80mm, min. depth 200
- Woodchip – grain size 5 do 30 mm, min. depth 200mm
- Sand – grain size 0,2 do 2 mm, min. depth 200mm
- Gravel – grain size 2 do 8 mm, min. depth 200 mm
- Synthetic surfaces in accordance with tested HIC (EN 1177)

The impact attenuating surfacing shall be installed on the whole of impact area.

A loose-fill safety surface shall be 100mm thicker than min. depth indicated above.

Technical description

- All posts made of closed profiles 100x100x3mm
- Bars and ladder made of Ø33,7x4mm pipes
- Horizontal ladder made of pipes: Ø38x4mm and Ø33,7x4mm
- Exercise pole and parallel bars made Ø38x4mm pipes
- Push-up bars made of Ø48,3x2,9mm pipes
- Seat of the exercise bench made of 15mm HDPE sheet
- All steel elements are hot-dip galvanized and painted with an acrylic, structured lacquer
- The set includes foundations made of concrete class C25/30
- All posts shall be set in concrete class C16/20

TECHNICAL DATA SHEET

Components of the Set

- Exercise bench with small ladder – 1pc.
- Double parallel bars – 1 set
- Horizontal ladder – 1pc.
- Ladder – 1 pc.
- Exercise pole – 1 pc.
- Push-up bars – 1 set
- Pull-up bar – 5 pcs.

Product visualization

