

# TECHNICAL DATA SHEET

## Mini Golf Lane Series

<b>Length of lanes</b>	L = 3 to 8 m*
<b>Width of standard lanes</b>	S = 0,5 do 1,0 m

\* it is possible to make tracks of other lengths on request,

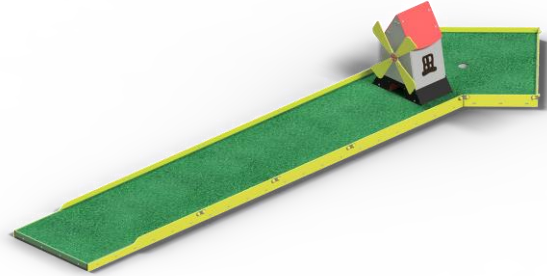

### Construction of lanes

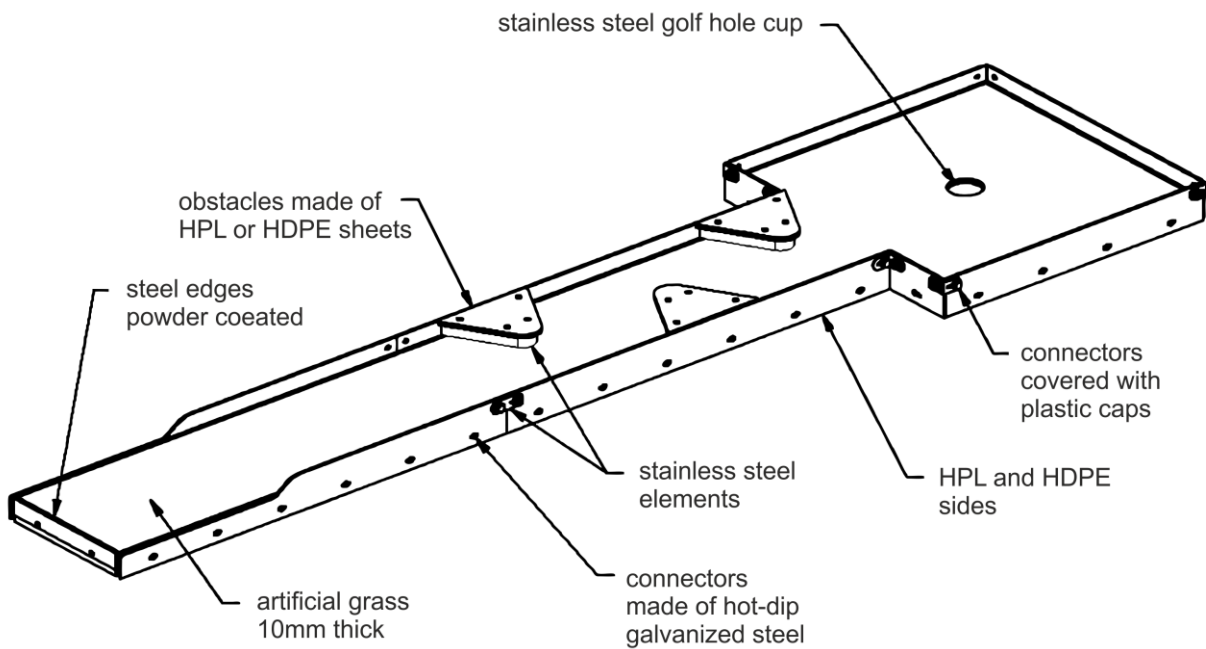

### Bottom view - Base

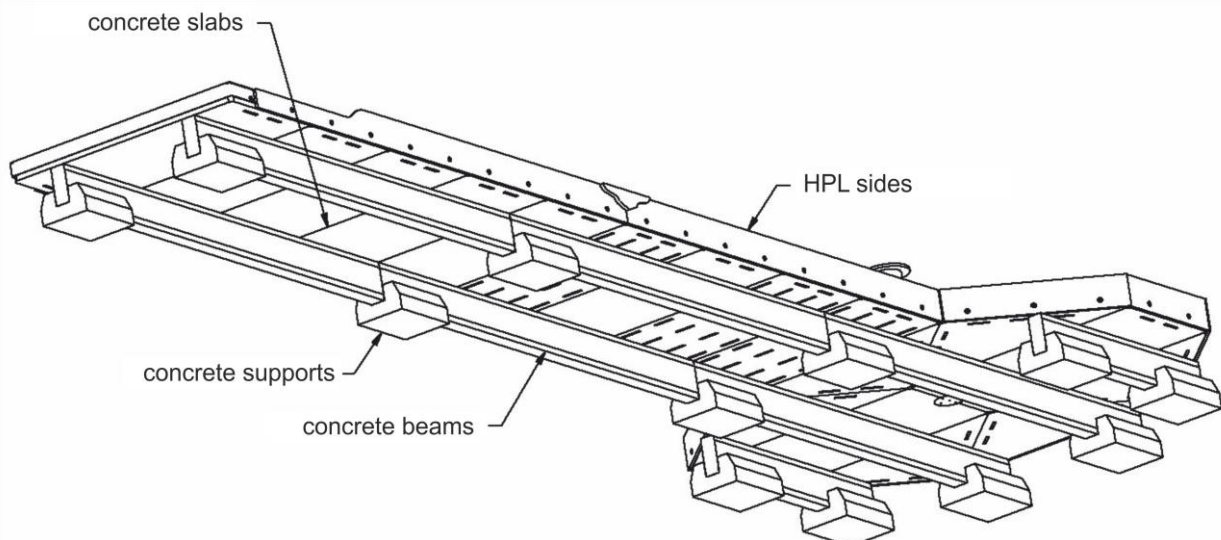

## Technical description

- Lanes are available in a wide range of shapes and with different obstacle
- Construction made of easily assembled prefabricated slabs, based on levelled concrete beams
- Sides of a lane made of HPL sheet, and sides of bumps made of HDPE sheet
- Obstacles made of stainless steel, HDPE and HPL sheet
- Connecting elements made of hot-dip galvanized steel
- Durable artificial grass 10mm thick
- We also offer accessories such as: golf clubs, golf balls, information boards and scoreboard

## Available types of lanes

### Mini Golf

Lanes with standard width 1m

*Samples*

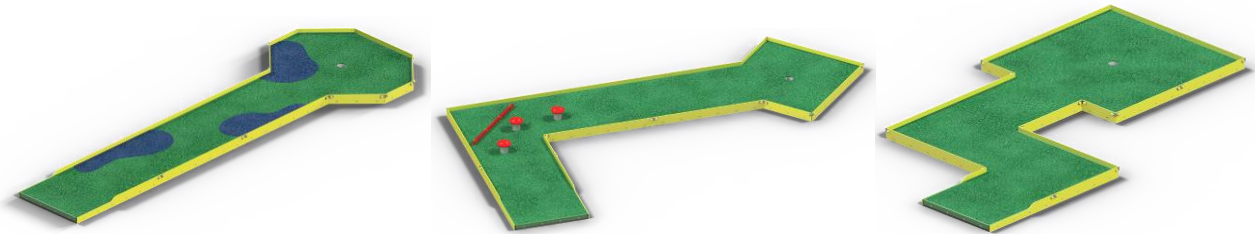

### Micro Golf

Lanes with standard width 0,5m

*Samples*

