

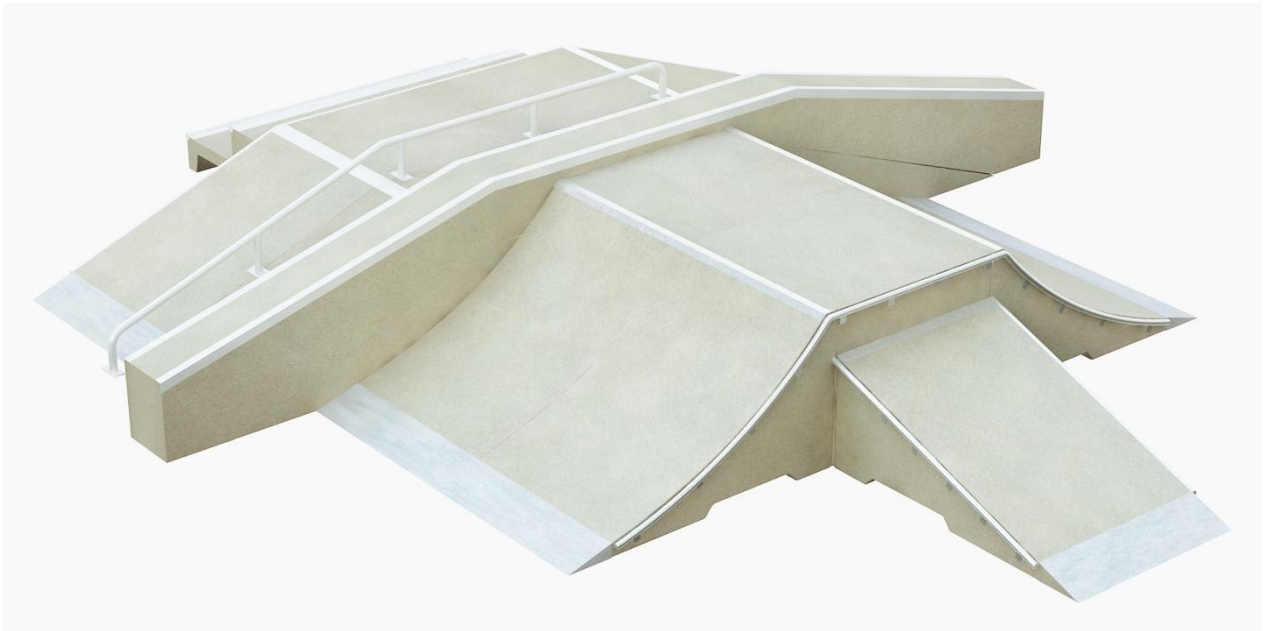

It shall apply from: 12-06-2015 r.

**THE ASSEMBLY INSTRUCTION OF:
Fun-Box 6
PRODUCT CODE: 107670**

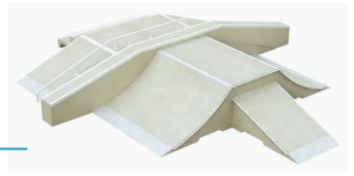



STAGE 1 – Preparatory work/safety zone

- Secure the assembly site to keep others at a distance
- Set the construction in a designated place having regard to required impact area.
- Mark approximate contact points between poles and ground

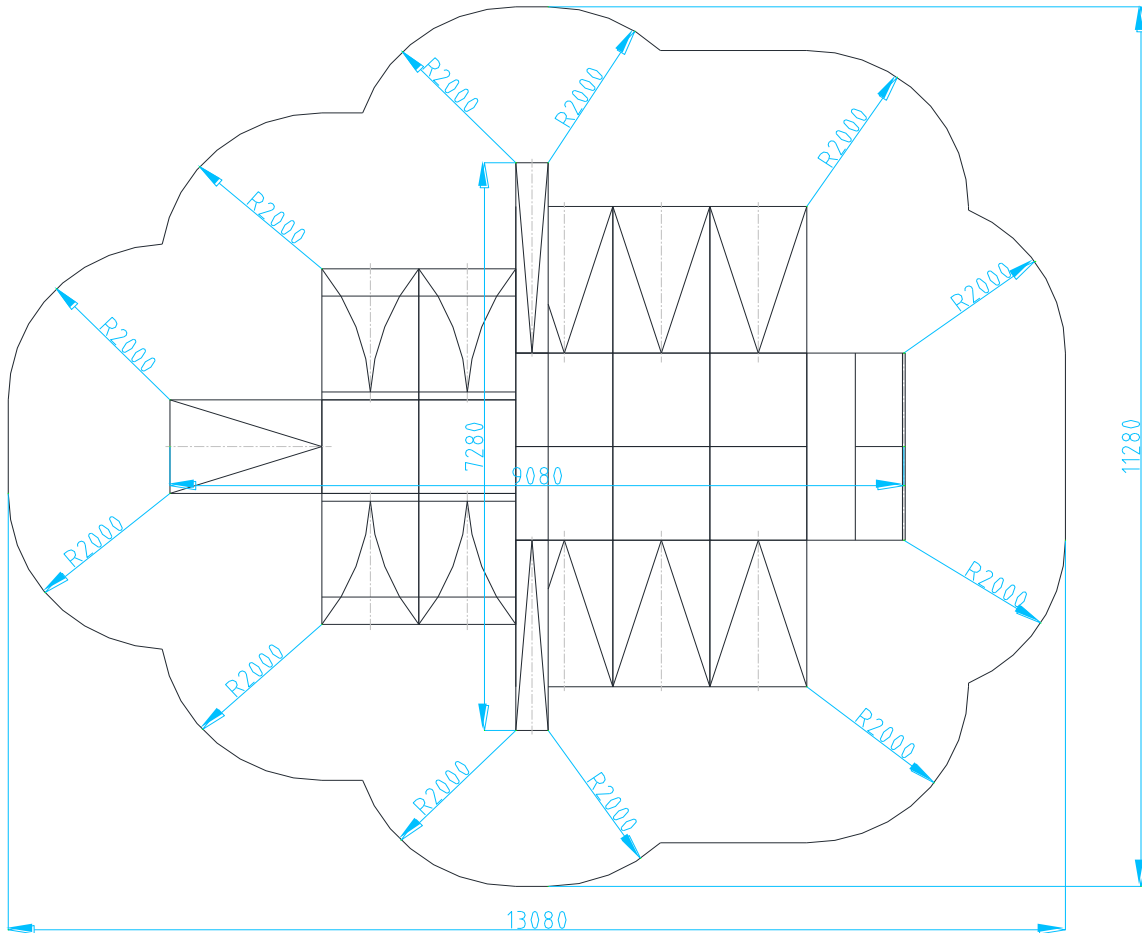

WARNING!

Installation shall be performed in accordance with safety & health standards

STAGE 2 – Assembly of the construction

1. List of components

No.	Name of component	Qty.
1	Box 700	6
2	Box 980	2
3	Bank 700	7
4	Grind Box 700 slanted	2
5	Grind Box straight	2
6	Rail	1
7	Olly Box Three-Piece	1
8	Ramp	4



2. Assembly scheme

- Screw the steel toe plates with a length of 350mm to the Ramps, according to the figure below
- Screw the steel toe plates with a length of 250mm to the Banks, according to the figure below

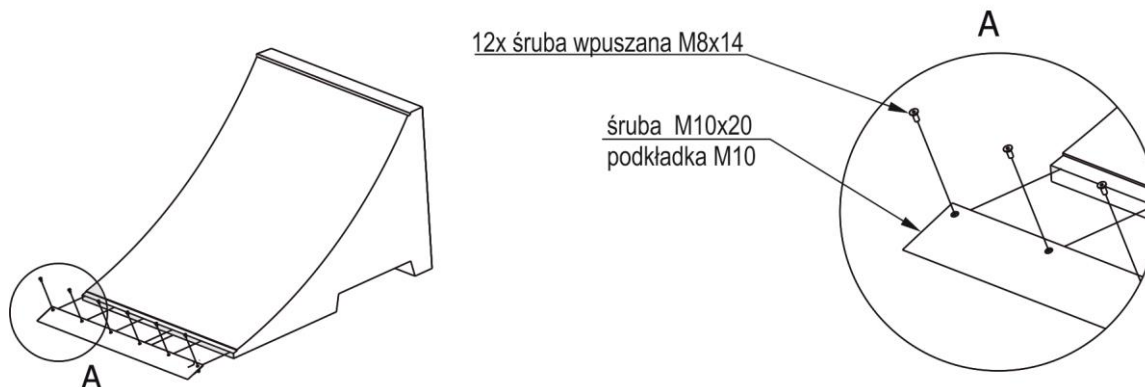

- Set the concrete elements according to the figure below:

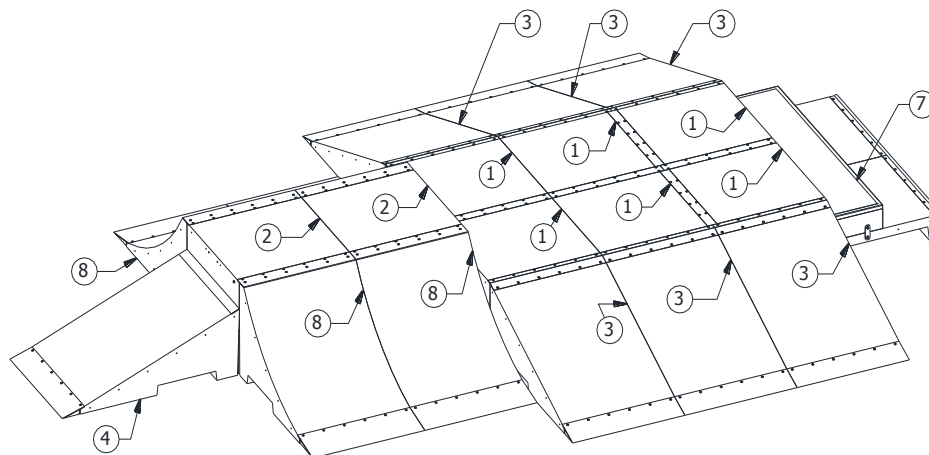

- Screw the connecting steel sheets

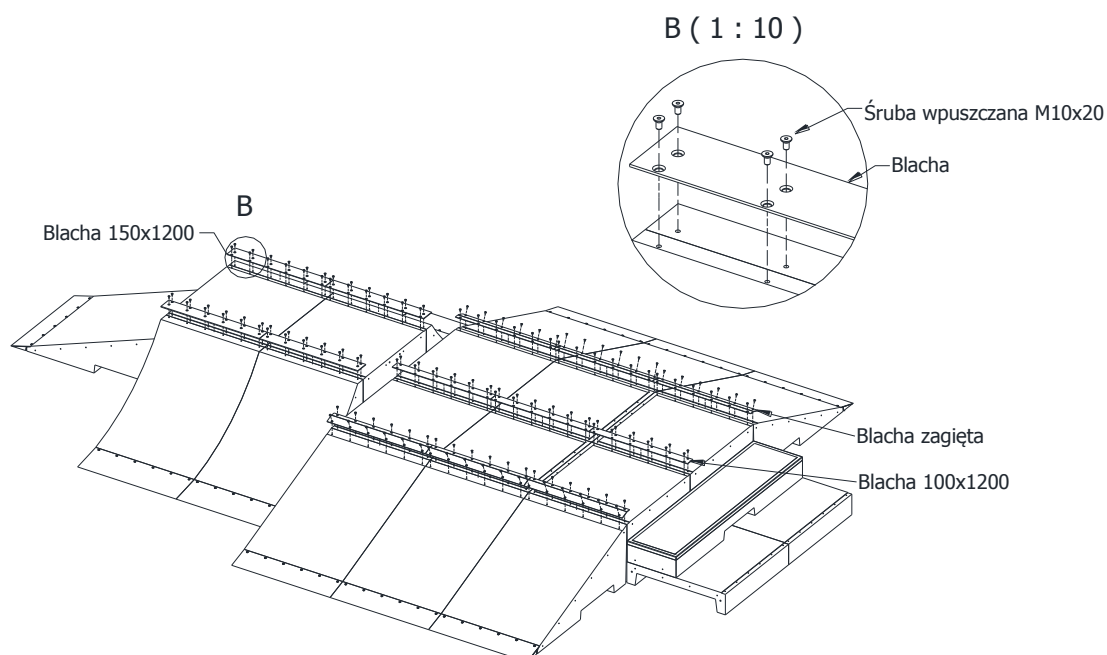



- Place the Grind box on an appropriate location and screw it in accordance with the figure below. Screw the Olly Box and the rails by using connecting steel sheets.

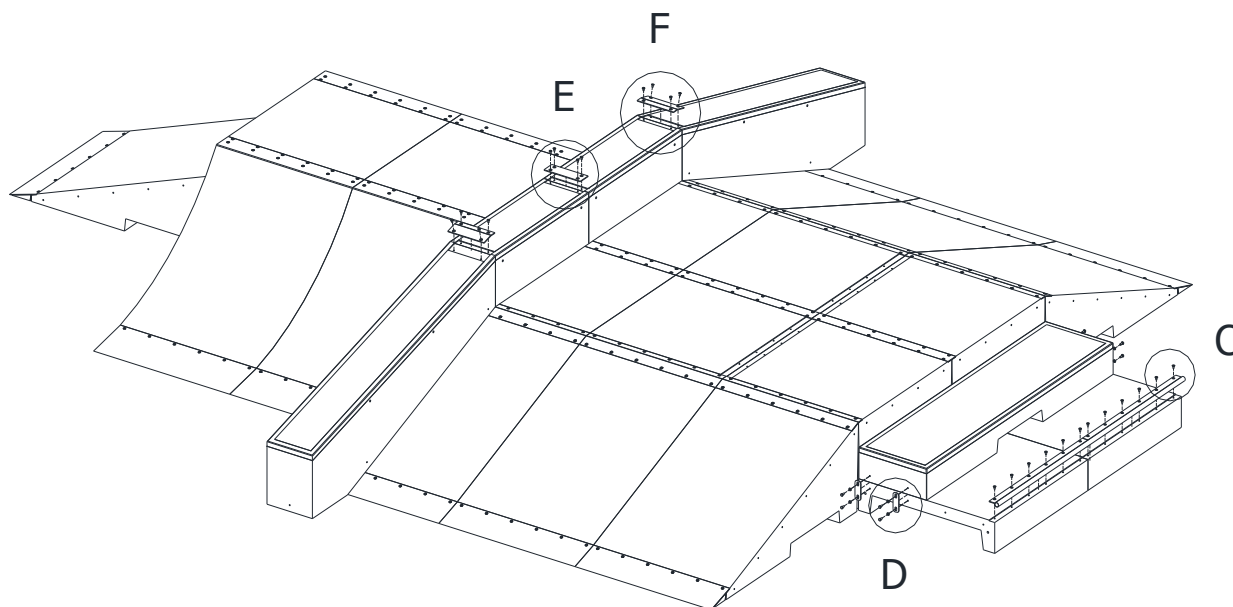

C (1 : 10)

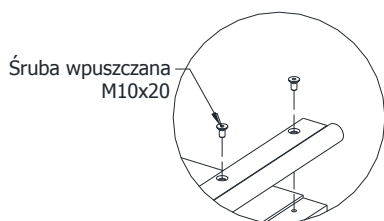

D (1 : 10)

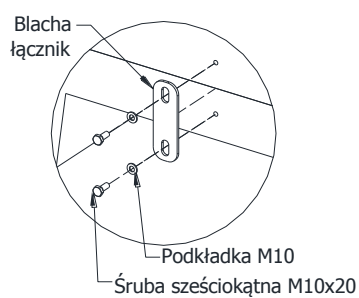

E (1 : 10)

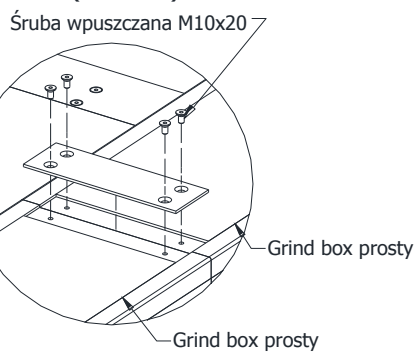

F (1 : 10)

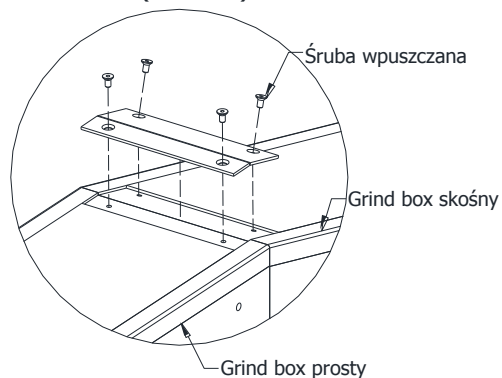

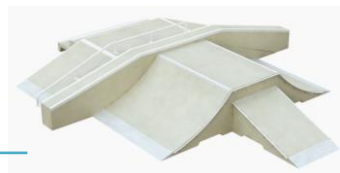

- Install the side rails according to the figure below:

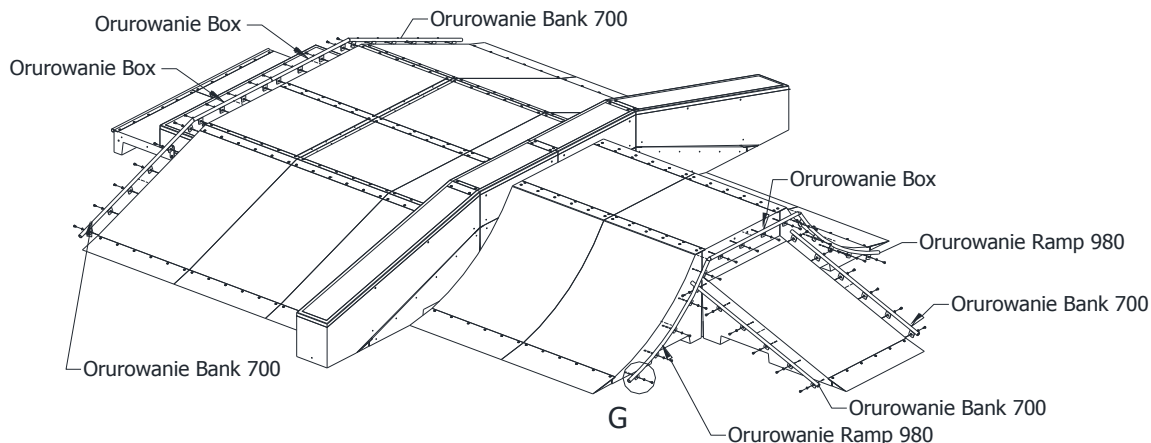

G (1 : 10)

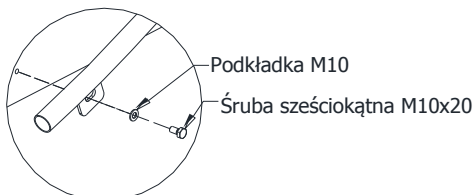

- Install the Rail by using countersunk screws M10x20. The end of the Rail shall be mounted in the ground and concreted with concrete of class C25/30.

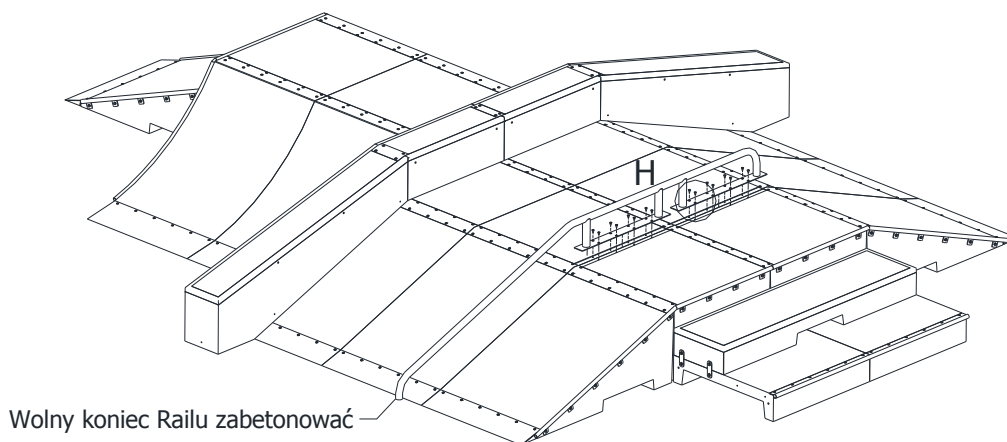

H (1 : 10)

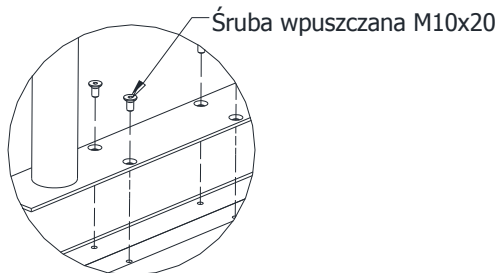

- Remove the slacks in joints
- Put the statutory plate