

HORSE RACING

Catalogue number: 14060

It shall apply from: 18-07-2017

Max. free fall height:	0,78 m
Product Dimensions: (length x width x height)	8,38 x 4,38 x 1,14 m
Impact area: (length x width)	11,38 x 7,38 m
Free zone:	71,7 m ²



Product dimensions:

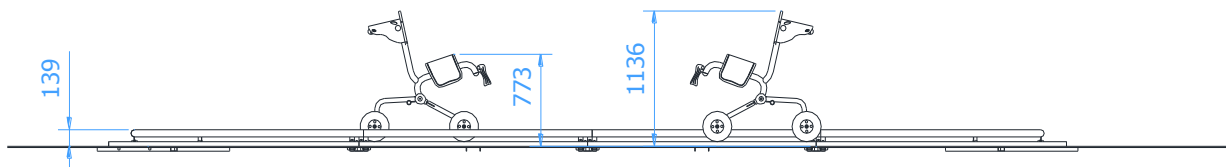

Impact area dimensions:

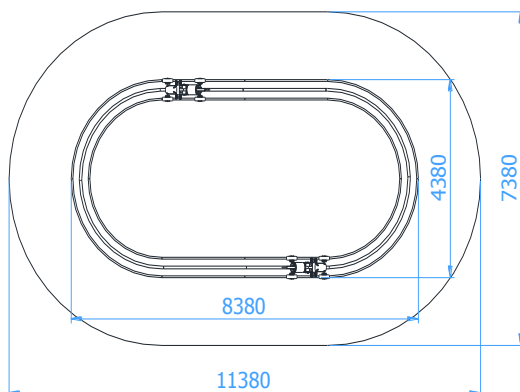

Acceptable shock-absorbing surface:

- Turf
- Bark – grain size 20 do 80mm, min. depth 200
- Woodchip – grain size 5 do 30 mm, min. depth 200mm
- Sand – grain size 0,2 do 2 mm, min. depth 200mm
- Gravel – grain size 2 do 8 mm, min. depth 200 mm
- Synthetic surfaces in accordance whit tested HIC (EN 1177)

The impact attenuating surfacing shall be installed on the whole of impact area.

A loose-fill safety surface shall be 100mm thicker than min. depth indicated above.

Opis techniczny

- The racetrack made of steel profiles 40x40x3mm, 40x80x3mm and stainless steel pipe: Ø60,3x2,6mm
- The vehicle made of steel pipes Ø48,3x2,9 and Ø38x2,6mm
- Surface elements of the vehicle made of 10mm HDPE sheet
- The user set in motion the vehicle by bouncing on it
- All steel elements are protected against corrosion and painted with an acrylic lacquer
- The set includes a foundation made of concrete of class C25/30 which make installation easier

Product visualization

