

HORSE SPRING ROCKER

Catalogue number: 22060

It shall apply from: 16-06-2020

Max. free fall height:	0,48 m
Product Dimensions: (length x width x height)	0,81 x 0,29 x 0,76 m
Impact area dimensions: (length x width)	3,21 x 2,69 m
Free zone	9,1 m ²

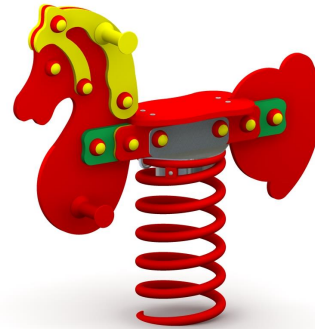

Product dimensions

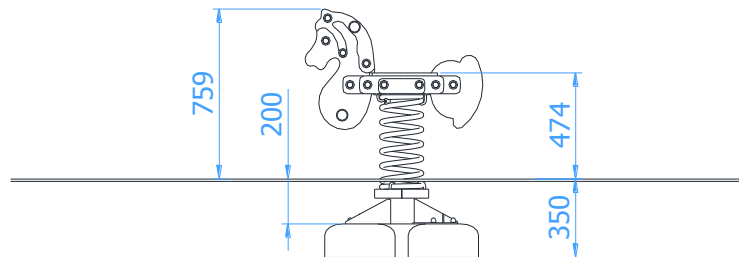

Impact area dimensions

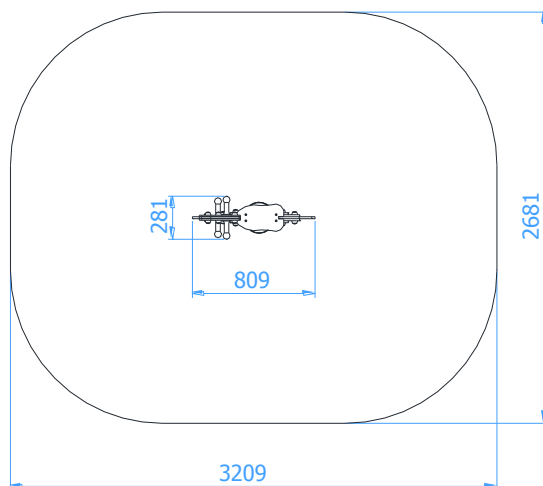

Permissible impact attenuating surface

- Turf
- Bark – grain size 20 do 80mm, min. depth 200
- Woodchip – grain size 5 do 30 mm, min. depth 200mm
- Sand – grain size 0,2 do 2 mm, min. depth 200mm
- Gravel – grain size 2 do 8 mm, min. depth 200 mm
- Synthetic surfaces in accordance with tested HIC (EN 1177)

The impact attenuating surfacing shall be installed on the whole of impact area.

A loose-fill safety surface shall be 100mm thicker than min. depth indicated above.

Technical description

- Construction made of steel pipe $\varnothing 114,3 \times 4$ mm and sheet metal 5 mm thick,
- Rocker Surface made of HDPE board 13 mm thick,
- All steel elements are hot-dip galvanized and painted with an acrylic, structured lacquer,
- The set includes foundations made of concrete class C25/30.

Product visualization

