

INSTALLATION INSTRUCTIONS WHEELCHAIR ACCESSIBLE STANDARD PLAYGROUND SET NO. 03

Catalogue number 70073, 78073

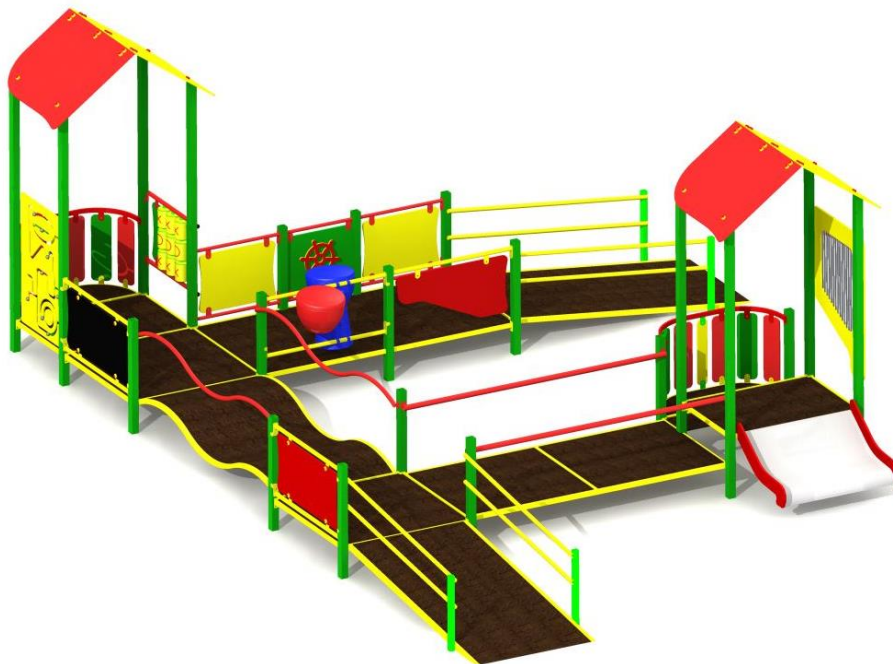
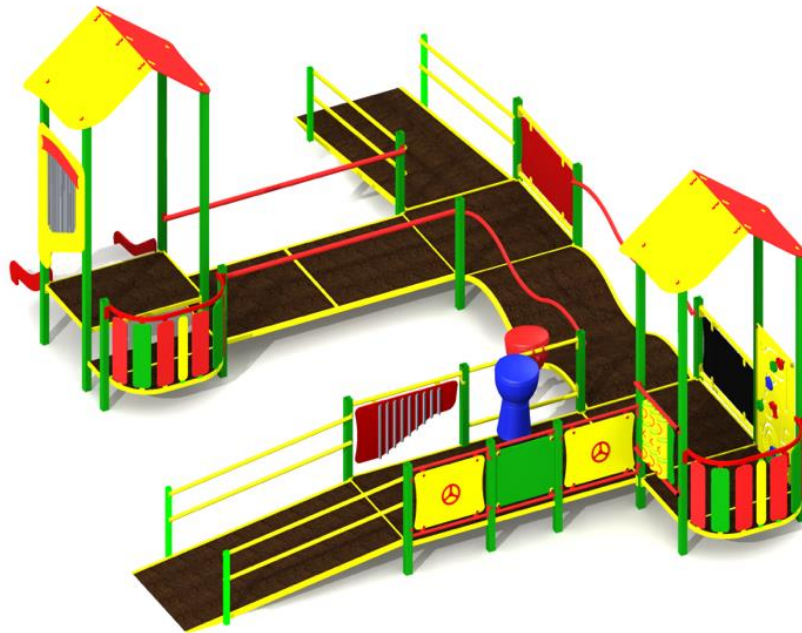



TABLE OF CONTENTS

Introduction.....	2
STAGE 1 – determining the place of assembly	3
STAGE 2 – assembly of the structure	4
1. Preparation of holes for foundations	4
2. Assembly of the structure	4

Introduction

User age:	up to 14 years
Max. free fall height:	0,30 m
Dimensions of the playground (length x width x height)	6,56 x 9,02 x 3,05 m
Dimension of the impact area (length x width)	9,40 x 12,02 m
Głębokość fundamentowania	0,35 m

Permissible impact attenuating surfacing

- Bark – any depth
- Woodchip – any depth
- Sand – any depth
- Gravel – any depth
- Synthetic surfaces in accordance with tested HIC (EN 1177)

The impact attenuating surfacing shall be installed on the whole of impact area.

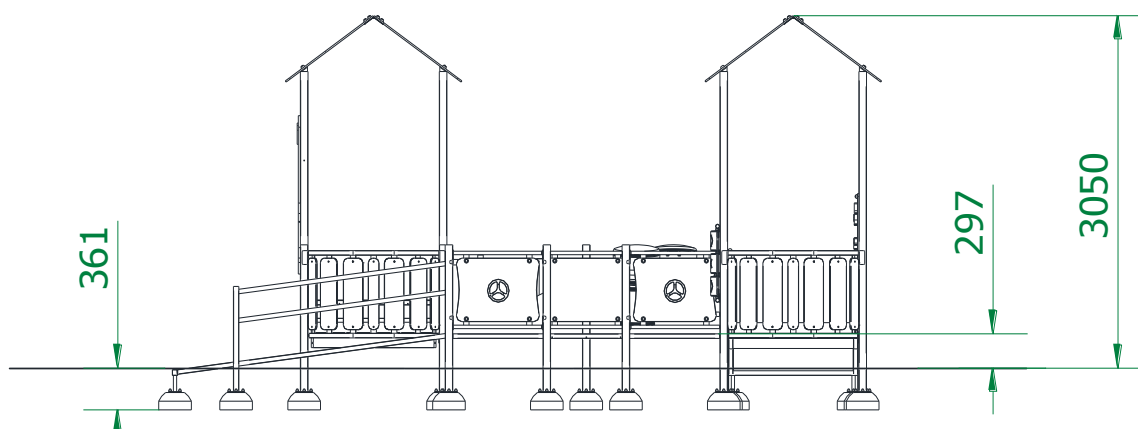

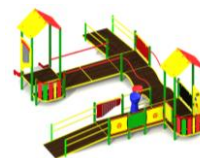

STAGE 1 – determining the place of assembly

- Secure the place of assembly work against unauthorized persons.
- Determine the place of assembly. Pay attention to the required impact surface.

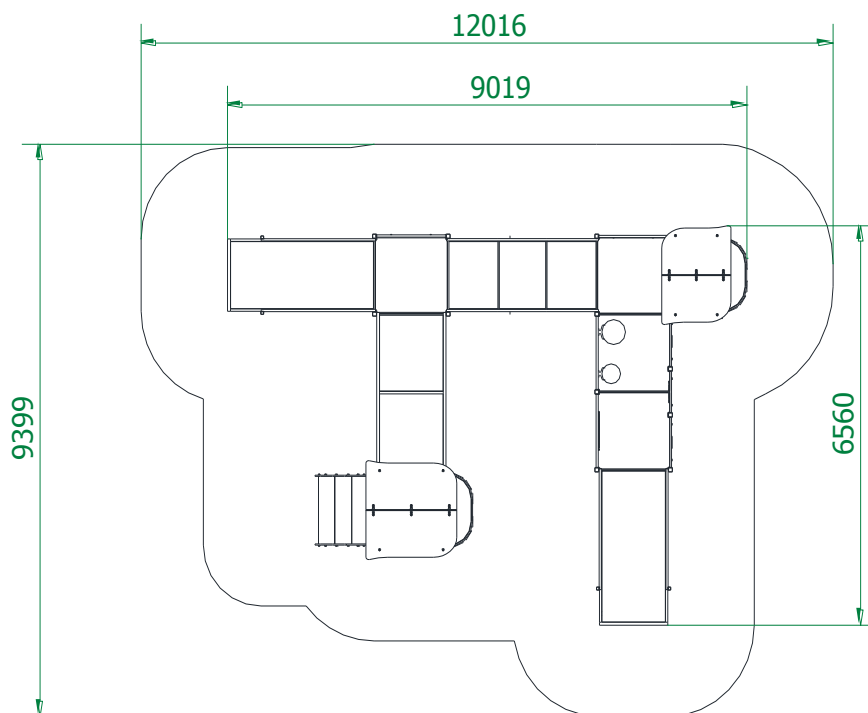

Attention !

A tolerance of ± 50 mm should be assumed in the foundation spacing.

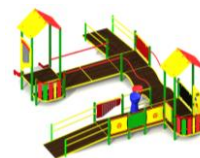

STAGE 2 – assembly of the structure

1. Preparation of holes for foundations

- Remove the turf at the place of assembly of foundations. Dig holes for the foundations of the right depth.
- If a synthetic surface is provided, it should be dig for whole of the surface including the right depth.
- Holes for foundations should be made larger by 200-300 mm. This will allow the implementation of possible correction settings.
- Insert the foundations of the tower into the openings

Attention !

Helpful drawing on Sheet.

2. Assembly of the structure

- Level the foundations to one another and ground level.
- Insert and bolt the pillars to the foundations.

Note: pay attention to the correct numbering of the pillars as shown in the drawing on Sheet 1/5.

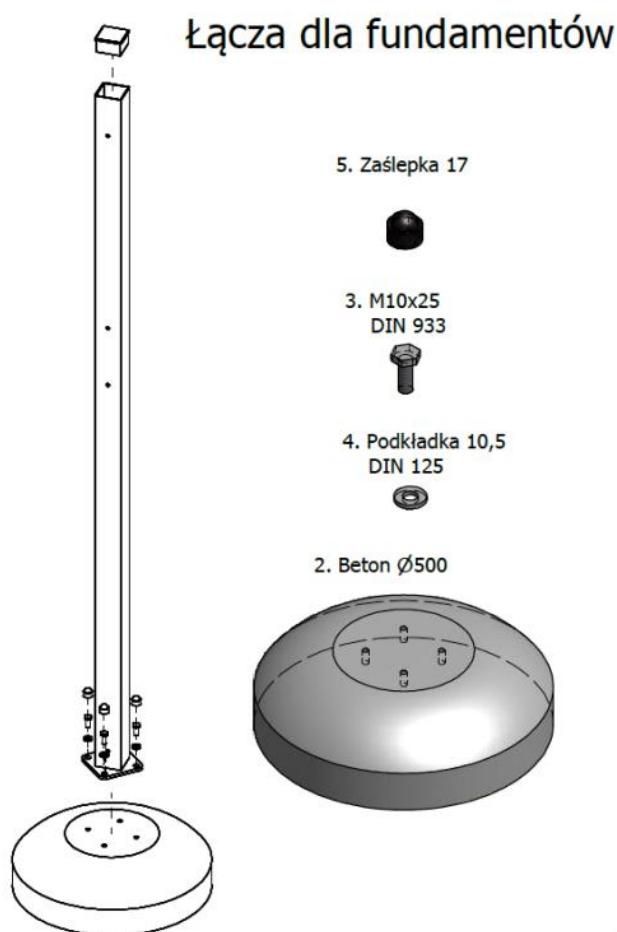

- Check the initial position of the pillars.
- Checking if the base level sign coincides with the ground level and make any corrections

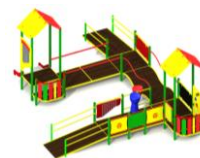

- Mount the platforms to the pillars.
- After mounting each platform, check the vertical and horizontal position of the structure.

Łącza dla podestów, barier, osłon, przewężeń, pomostów, wejść. J (1 : 5)

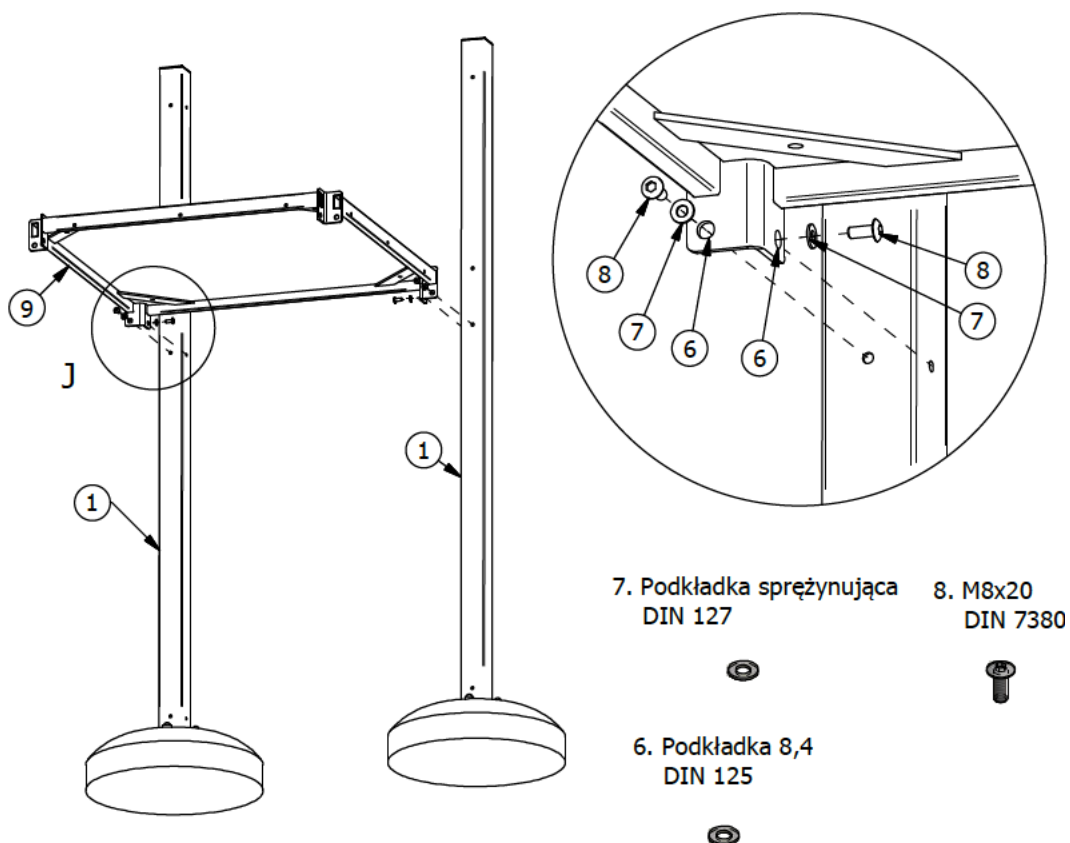

- Mount the barriers and shields to the sides of the tower.
- Mount the other modules to the sides of the tower: platforms, entrances, slides, etc.
- Cover the holes by compacting every 100 mm.
- Make the synthetic surfaces. If present.
- Install the nameplate
- **Go for a good beer!.**