

Technical Data Sheet



Product name:
Round Concrete Card Table with 8 seats

Date create:
2015-05-20

Code:
7200

Destination:
Urban Furniture

Scale:
1:25

Construction materials:
Concrete, exotic wood, steel elements

Weight:
1210kilos

Notes:
In-ground mounted, \varnothing 1200mm

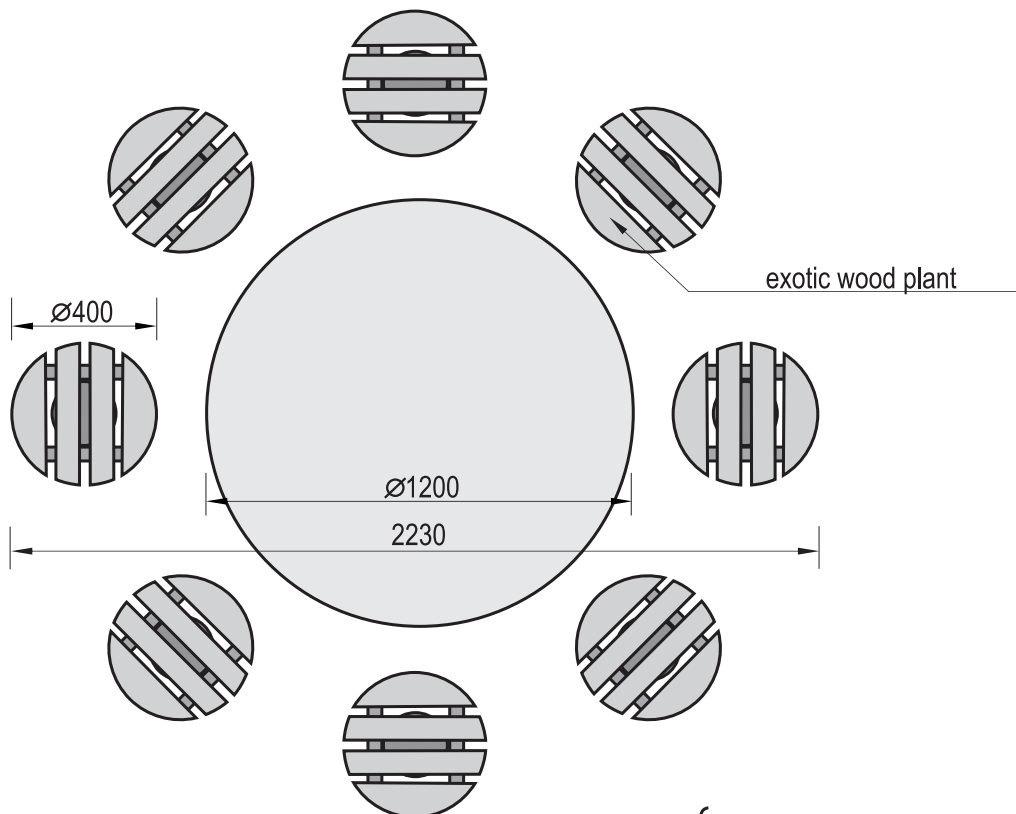
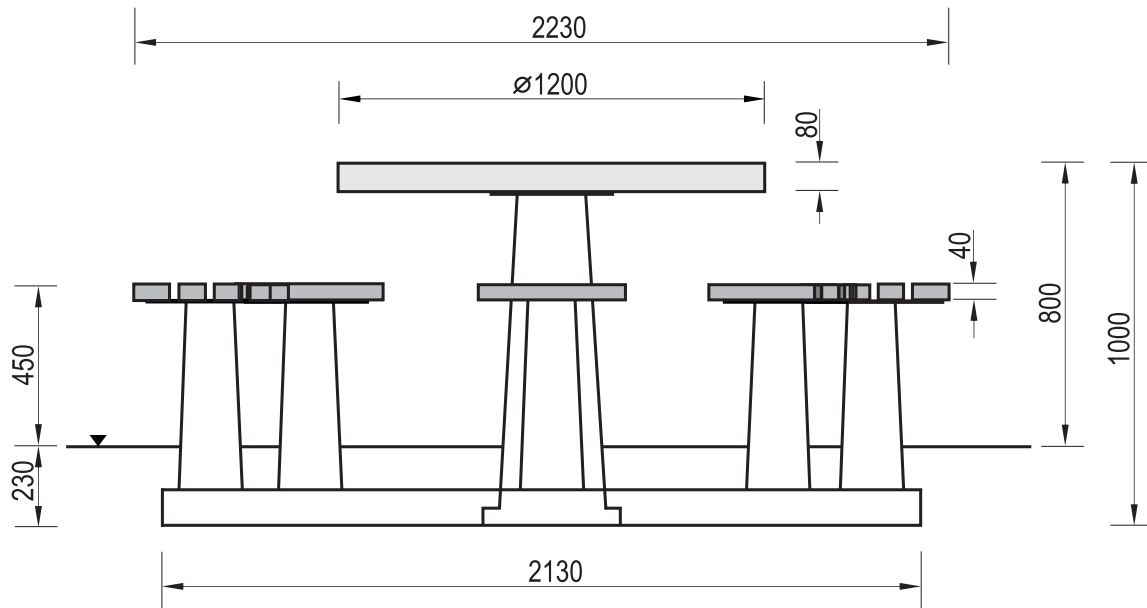

Technical description:

- Designed specifically for outdoor use
- Available only with plain top
- Construction made of high quality, vibrated and reinforced concrete class C25/30
- Seats made of lacquered exotic wooden planks resistant to weather conditions
- Top of the table protected by aluminum edge trims
- Polished and enamel flat is highly resistant to weather conditions

WARNING ! The equipment shall be used in accordance with its intended purpose