

STREET WORKOUT SET NO. 2

Catalogue number: 88002

It shall apply from: 22-01-2024

Max. free fall height:	1,30 m
Product Dimensions: (length x width x height)	5,02 x 1,50 x 2,30 m
Impact area: (length x width)	8,05 x 4,50 m
Free zone:	34,1 m ²

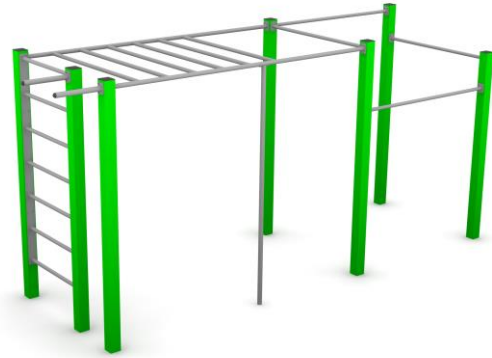

Product dimensions

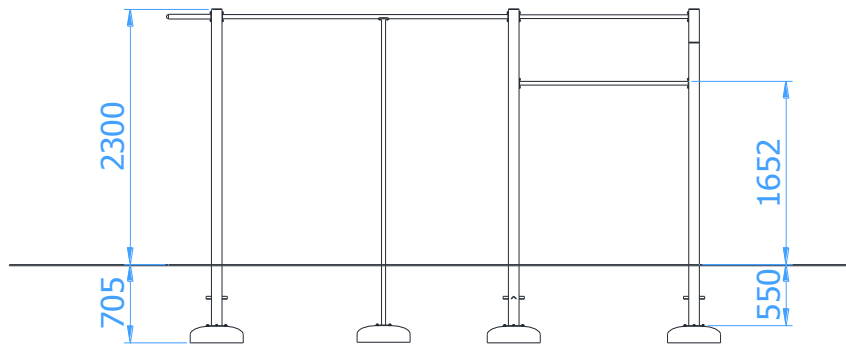

Impact area dimensions

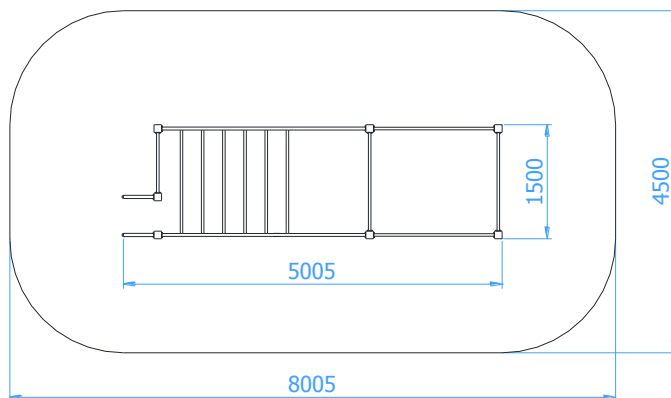

Permissible impact attenuating surface

- Bark – grain size 20 do 80mm, min. depth 200mm
- Woodchip – grain size 5 do 30 mm, min. depth 200mm
- Sand – grain size 0,2 do 2 mm, min. depth 200mm
- Gravel – grain size 2 do 8 mm, min. depth 200 mm
- Synthetic surfaces in accordance with tested HIC (EN 1177)

The impact attenuating surfacing shall be installed on the whole of impact area.

A loose-fill safety surface shall be 100mm thicker than min. depth indicated above.

Technical description

- All posts made of closed profiles 100x100x3mm
- Bars and the horizontal ladder made of $\varnothing 33,7 \times 4$ mm pipes
- Horizontal ladder made of $\varnothing 33,7 \times 4$ mm and $\varnothing 38 \times 4$ mm pipes
- All steel elements are hot-dip galvanized and painted with an acrylic, structured lacquer
- The set includes foundations made of concrete class C25/30
- All posts shall be set in concrete class C16/20

TECHNICAL DATA SHEET

Components of the Set

- Pull-up bar – 5 pcs.
- Horizontal ladder – 1 pc.
- Ladder – 1 pc.
- Exercise pole – 1 pc.

Product visualization

