

## STREET WORKOUT SET NO. 8

Catalogue number: 88008

It shall apply from: 22-01-2024

<b>Max. free fall height:</b>	2,80 m
<b>Product Dimensions:</b> (length x width x height)	7,59 x 7,99 x 3,90 m
<b>Impact area:</b> (length x width)	11,19 x 10,99 m
<b>Free zone:</b>	102,3 m <sup>2</sup>

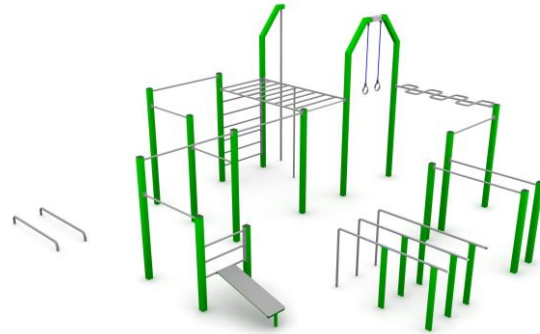

### Product dimensions

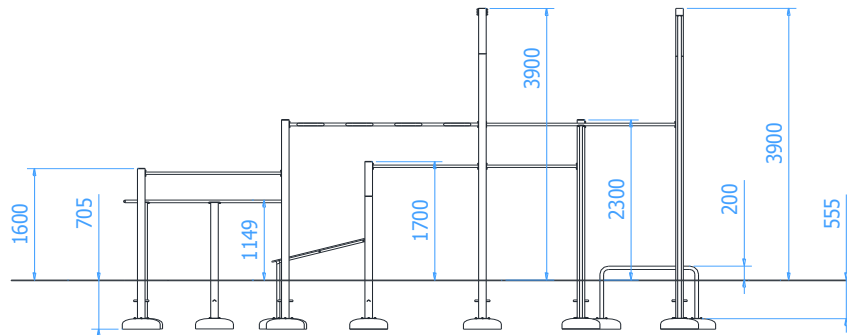

### Impact area dimensions

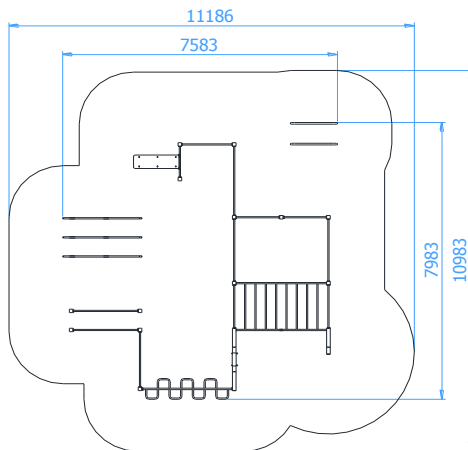

### Permissible impact attenuating surface

- Bark – grain size 20 do 80mm, min. depth 200
- Woodchip – grain size 5 do 30 mm, min. depth 200mm
- Sand – grain size 0,2 do 2 mm, min. depth 200mm
- Gravel – grain size 2 do 8 mm, min. depth 200 mm
- Synthetic surfaces in accordance whit tested HIC (EN 1177)

*The impact attenuating surfacing shall be installed on the whole of impact area.  
A loose-fill safety surface shall be 100mm thicker than min. depth indicated above.*

### Technical description

- All posts made of closed profiles 100x100x3mm
- Bars made of  $\varnothing 33,7 \times 4$ mm pipes
- Gymnastic rings made of stainless steel pipe  $\varnothing 30 \times 2$ mm and armed rope  $\varnothing 16$ mm
- Exercise pole and push-up bars made of pipe  $\varnothing 48,3 \times 2,9$ mm
- Seat of the exercise bench made of 15mm HDPE sheet
- All steel elements are hot-dip galvanized and painted with an acrylic, structured lacquer
- The set includes foundations made of concrete class C25/30
- All posts shall be set in concrete class C16/20

## TECHNICAL DATA SHEET

### Components of the Set

- Exercise bench with small ladder – 1 pc.
- Triple parallel bars – 1 set
- Double parallel bars – 1 set
- Ladder – 1 pc.
- Horizontal ladder – 1 pc.
- Horizontal snake ladder – 1 pc.
- Exercise pole – 2 pcs.
- Gymnastic rings – 1 set
- Push-up bars – 1 set
- Pull-up bar – 7 pcs.

### Product visualization

