

STREET WORKOUT SET NO. 22

Catalogue number: 88022

It shall apply from: 22-01-2024

| | |
|---|-----------------------|
| Max. free fall height: | 2,80 m |
| Product Dimensions: (length x width x height) | 10,13 x 4,07 x 3,90 m |
| Impact area: (length x width) | 14,01 x 10,87 m |
| Free zone: | 75,7 m ² |

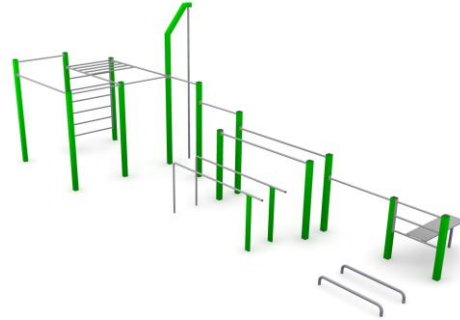

Product dimensions

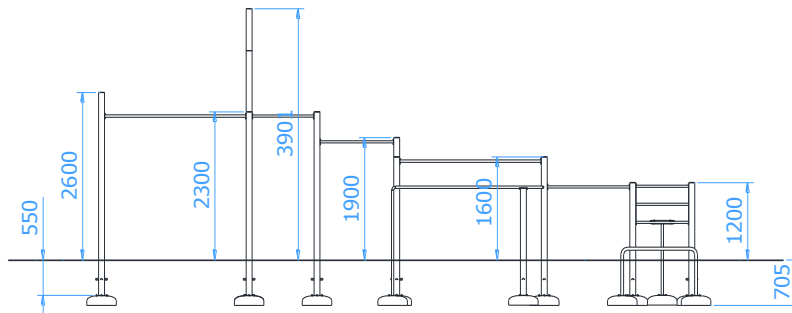

Impact area dimensions

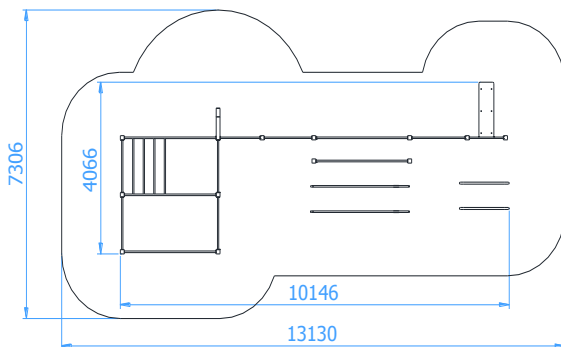

Permissible impact attenuating surface

- Bark – grain size 20 do 80mm, min. depth 200
- Woodchip – grain size 5 do 30 mm, min. depth 200mm
- Sand – grain size 0,2 do 2 mm, min. depth 200mm
- Gravel – grain size 2 do 8 mm, min. depth 200 mm
- Synthetic surfaces in accordance whit tested HIC (EN 1177)

The impact attenuating surfacing shall be installed on the whole of impact area.

A loose-fill safety surface shall be 100mm thicker than min. depth indicated above.

Technical description

- All posts made of closed profiles 100x100x3mm
- Bars and ladders made of Ø33,7x4mm pipes
- Exercise pole made of Ø48,3x2,9mm pipe
- Horizontal ladder made of Ø33,7x4mm and Ø38x4mm pipes
- Seat of the exercise bench made of 15mm HDPE sheet
- All steel elements are hot-dip galvanized and painted with an acrylic, structured lacquer
- The set includes foundations made of concrete class C25/30
- All posts shall be set in concrete class C16/20

TECHNICAL DATA SHEET

Components of the Set

- Horizontal ladder – 1pc.
- Ladder – 1pc.
- Exercise bench with small ladder – 1pc.
- Pull-up bar – 7pcs.
- Parallel bars – 2sets
- Exercise pole – 1pc.
- Push-up bars – 1set

Product visualization

