

STREET WORKOUT SET NO. 27

Catalogue number: 88027

It shall apply from: 22-01-2024

Max. free fall height:	1,71 m
Product Dimensions: (length x width x height)	4,36 x 4,94 x 3,90 m
Impact area: (length x width)	8,06 x 7,51 m
Free zone:	47,0 m ²

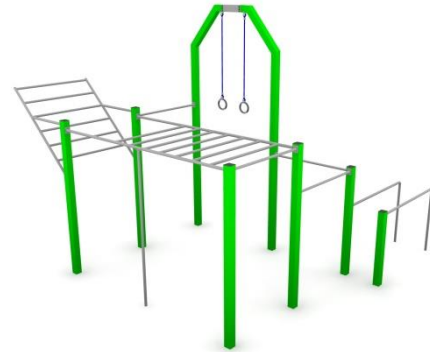

Product dimensions

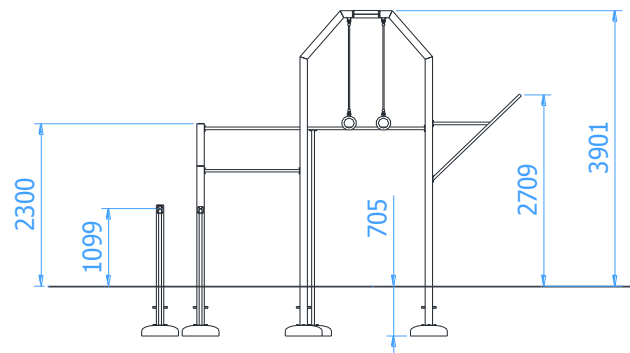

Impact area dimensions

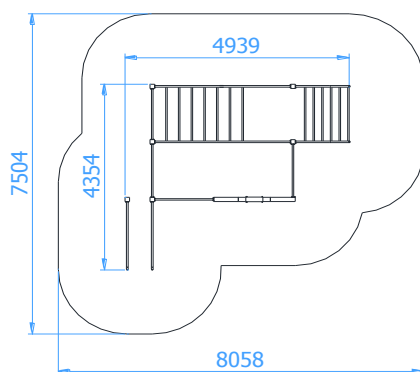

Permissible impact attenuating surface

- Bark – grain size 20 do 80mm, min. depth 200
- Woodchip – grain size 5 do 30 mm, min. depth 200mm
- Sand – grain size 0,2 do 2 mm, min. depth 200mm
- Gravel – grain size 2 do 8 mm, min. depth 200 mm
- Synthetic surfaces in accordance whit tested HIC (EN 1177)

*The impact attenuating surfacing shall be installed on the whole of impact area.
A loose-fill safety surface shall be 100mm thicker than min. depth indicated above.*

Technical description

- All posts made of closed profiles 100x100x3mm
- Bars made of $\varnothing 33,7 \times 4$ mm pipes
- Gymnastic rings made of stainless steel pipe $\varnothing 30 \times 2$ mm and armed rope $\varnothing 16$ mm
- Exercise pole made of $\varnothing 38 \times 4$ mm pipe
- Horizontal ladder made of $\varnothing 33,7 \times 4$ mm and $\varnothing 38 \times 4$ mm pipes
- All steel elements are hot-dip galvanized and painted with an acrylic, structured lacquer
- The set includes foundations made of concrete class C25/30
- All posts shall be set in concrete class C16/20

TECHNICAL DATA SHEET

Components of the Set

- Double parallel bars – 1 set
- Horizontal ladder – 1 pc.
- Slanted ladder – 1 pc.
- Exercise pole – 1 pc.
- Gymnastic rings – 1 set
- Pull-up bar – 3 pcs.

Product visualization

