

MONKEY RACING I

Hanging exercise circular machine

Catalogue number: 88300

It shall apply from: 30-03-2016

Max. free fall height:	0,98 m
Product Dimensions: (length x width x height)	2,70 x 2,70 x 2,95 m
Impact area: (length x width)	Ø5,69 m
Free zone:	25,4 m ²

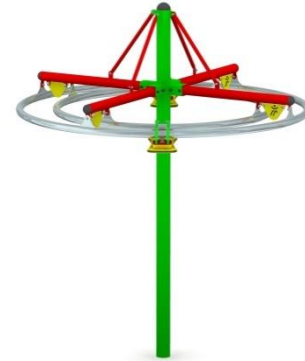

Product dimensions

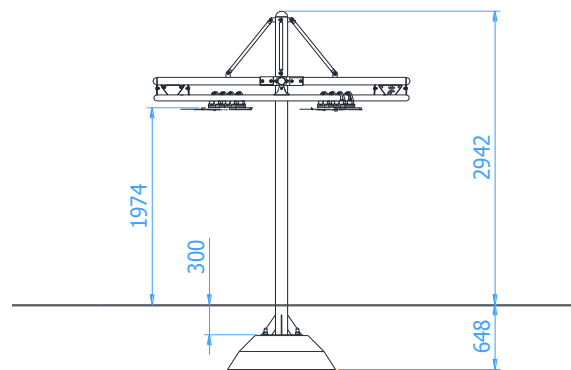

Impact area dimensions

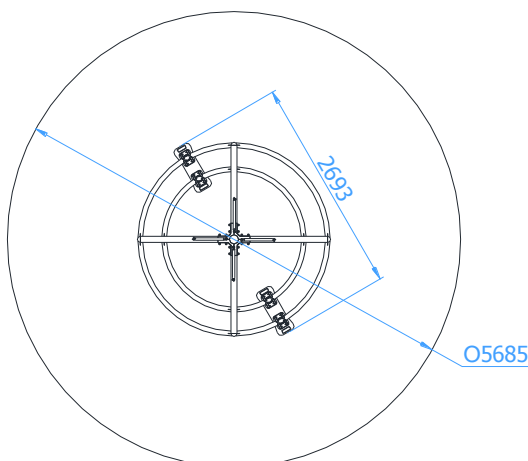

Permissible impact attenuating surface

- Bark – grain size 20 do 80mm, min. depth 200
- Woodchip – grain size 5 do 30 mm, min. depth 200mm
- Sand – grain size 0,2 do 2 mm, min. depth 200mm
- Gravel – grain size 2 do 8 mm, min. depth 200 mm
- Synthetic surfaces in accordance whit tested HIC (EN 1177)

The impact attenuating surfacing shall be installed on the whole of impact area.

A loose-fill safety surface shall be 100mm thicker than min. depth indicated above.

TECHNICAL DATA SHEET

Technical description

- Construction made of steel profile 70x70x3mm and a steel pipe $\varnothing 60,3 \times 2,9$ mm
- Guideway made of stainless steel profile 70x70x3mm
- Handles made of 19mm HDPE sheet
- All steel elements are protected against corrosion and painted with an acrylic lacquer
- The set includes foundations made of concrete class C25/30
- All posts shall be set in concrete class C16/20

Product visualization

