

MONKEY RACING II

Hanging exercise oval machine

Catalogue number: 88310

It shall apply from: 30-03-2016

Max. free fall height:	0,98 m
Product Dimensions: (length x width x height)	4,55 x 2,41 x 2,95 m
Impact area: (length x width)	7,85 x 5,69 m
Free zone:	37,6 m ²

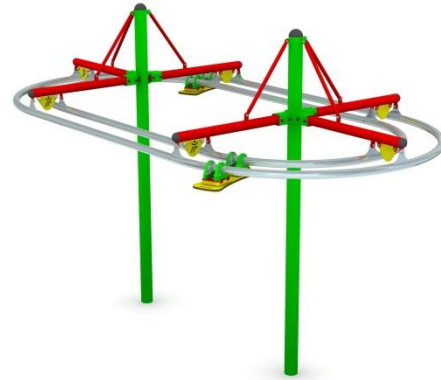

Product dimensions

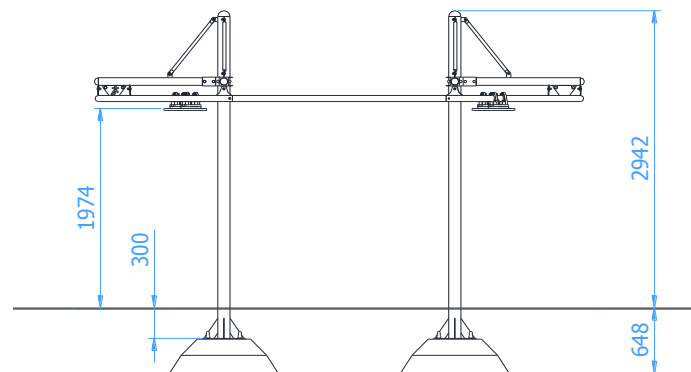

Impact area dimensions

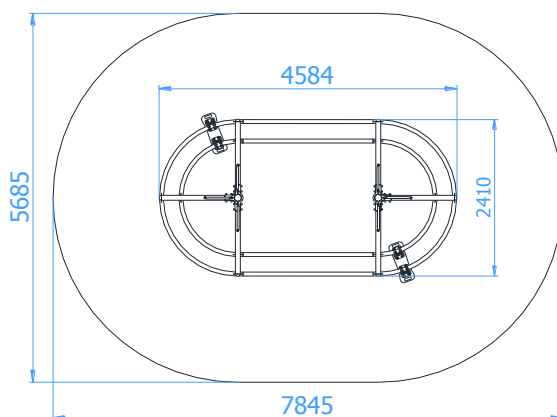

Permissible impact attenuating surface

- Concrete/Stone surface
- A bituminous Surface
- Bark – grain size 20 do 80mm, min. depth 200
- Woodchip – grain size 5 do 30 mm, min. depth 200mm
- Sand – grain size 0,2 do 2 mm, min. depth 200mm
- Gravel – grain size 2 do 8 mm, min. depth 200 mm
- Synthetic surfaces in accordance whit tested HIC (EN 1177)

The impact attenuating surfacing shall be installed on the whole of impact area.

A loose-fill safety surface shall be 100mm thicker than min. depth indicated above.

Technical description

- Construction made of pipes: $\varnothing 114,3 \times 4$ mm, $\varnothing 76,1 \times 3,2$ mm and $\varnothing 30 \times 2$ mm,
- Guideway made of stainless steel profile $\varnothing 60,3 \times 2,6$ mm
- Handles made of 19mm HDPE sheet
- All steel elements are protected against corrosion and painted with an acrylic lacquer
- The set includes foundations made of concrete class C25/30

TECHNICAL DATA SHEET

Product visualization

