

STREET WORKOUT & PARKOUR SET NO. 2

Numer katalogowy: 88502

It shall apply from: 24-01-2024

Max. free fall height:	2,06 m
Product Dimensions: (length x width x height)	7,58 x 7,02 x 2,30 m
Impact area: (length x width)	10,48 x 10,02 m
Free zone:	69,0 m ²



Product dimensions

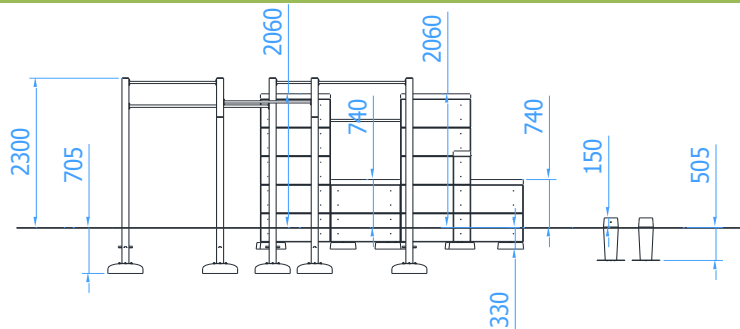

Impact area dimensions

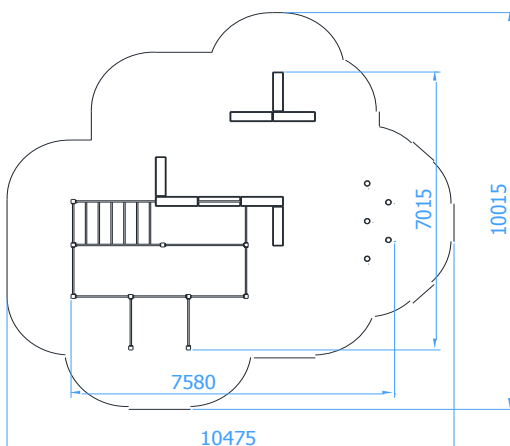

Permissible impact attenuating surface

- Bark – grain size 20 do 80mm, min. depth 200
- Woodchip – grain size 5 do 30 mm, min. depth 200mm
- Sand – grain size 0,2 do 2 mm, min. depth 200mm
- Gravel – grain size 2 do 8 mm, min. depth 200 mm
- Synthetic surfaces in accordance whit tested HIC (EN 1177)

The impact attenuating surfacing shall be installed on the whole of impact area.

A loose-fill safety surface shall be 100mm thicker than min. depth indicated above.

Technical description

- All posts made of closed profiles 100x100x3mm
- Bars and ladder made of Ø33,7x4mm pipes
- Horizontal ladder made of pipes: Ø38x4mm and Ø33,7x4mm
- Blocks made of concrete class C16/20
- All steel elements are hot-dip galvanized and painted with an acrylic, structured lacquer
- The set includes foundations made of concrete class C25/30
- All posts shall be set in concrete class C16/20

TECHNICAL DATA SHEET

Product visualization

