

WHEELCHAIR ACCESSIBLE SANBOX

Catalogue number: 910

It shall apply from: 05-02-2019

Max. free fall height:	0,63 m
Product Dimensions: (length x width x height)	2,20 x 2,20 x 0,63 m
Impact area (length x width)	Ø 5,20 m
Free zone	21,3 m ²



Product dimensions

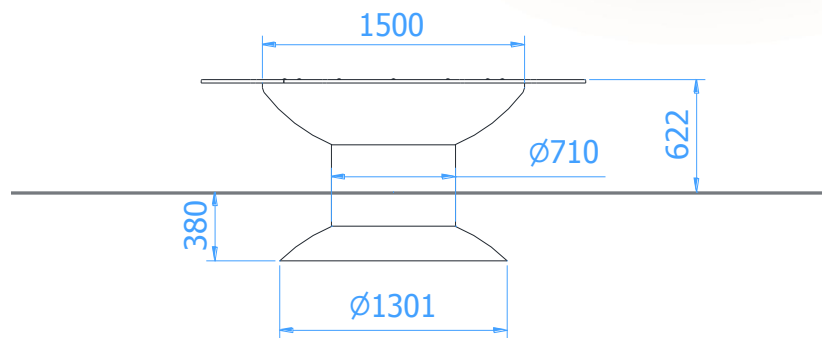

Impact area dimensions

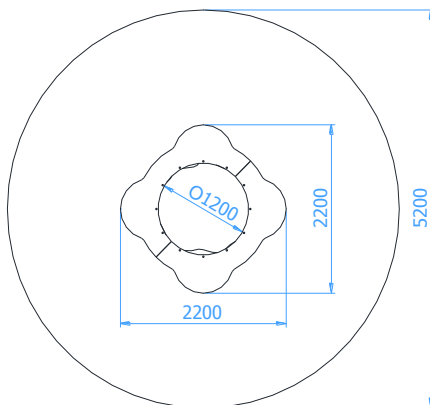

Recommended shock absorbing surface

- Turf
- Bark – grain size 20 do 80 mm, min. depth 200 mm
- Woodchip – grain size 5 do 30 mm, min. depth 200mm
- Sand – grain size 0,2 do 2 mm, min. depth 200mm
- Gravel – grain size 2 do 8 mm, min. depth 200
- Synthetic surfaces in accordance whit tested HIC (EN 1177)

The impact attenuating surfacing shall be installed on the whole of impact area.

A loose-fill safety surface shall be 100mm thicker than min. depth indicated above.

Technical description

- A durable construction made of high quality, painted concrete of class C25/30
- The top made of 19mm HDPE sheet
- Product designed to be available for special needs kids
- A positioning of the sanbox protects the sand against animal droppings
- All steel elements are protected against corrosion
- Includes a foundation made of concrete class C25/30 which make installation easier

Product visualization

